

## **INSTRUMENTATION AND CONTROL**

**K. E. Breymayer, K. F. Crook, E. V. Farinholt, Z. D. Farkas,  
L. Genova, H. A. Hogg, R. S. Larsen, M. J. Lee,  
K. B. Mallory, Editor, and D. D. Reagan**

Early in the history of SLAC, it was decided that the injector, the alignment system, and the beam switchyard should be developed as independent units. As a result, they are but weakly integrated with the instrumentation and control systems for the rest of the machine. They are discussed in detail in other chapters.

Instrumentation and control (I & C) includes the trigger and protection systems, which extend over the whole machine and are described in Chapters 14 and 21. It also includes a number of other systems extending from the injector to Sector 30. These systems, covered in this chapter, are data handling, central control, beam monitoring, guidance, and analysis systems, and local control and protection for klystrons and modulators. I & C also includes coordination of the multitude of interfaces between these systems and the injector, alignment system, phasing system, beam switchyard (BSY), water, power, and vacuum systems, discussed in other chapters.

### **15-1 Criteria and requirements**

#### *General criteria (KBM)*

The control system for the SLAC accelerator was largely shaped by two sets of criteria, one physical and one operational. The primary physical criteria are the 25-ft shielding requirement between the accelerator and maintenance people during operation, the 2-mile length of the machine, and the presence of a large number of noise sources such as the high-power modulators. The principal operational criteria are the requirement for multiple beams and the

need to centralize enough controls so that one person, possibly assisted by a computer, can operate the machine.

The accelerator housing is buried under 25 ft of shielding and is inaccessible while the machine is operating. Therefore, to the greatest extent possible, all equipment requiring maintenance (certainly all electronics) must be located in the gallery above. The gallery cannot be full of technicians; therefore, equipment must run unattended for long periods. The equipment must be self-protecting, self-resetting where feasible, and should give remote alarms calling for help when required. A large number of status monitoring signals is required to alert the operator to the existence of trouble and to indicate at least the first step toward repair.

The number of signals is so large and the distances are so great that multiplexing becomes an attractive method for handling both control and status monitoring signals. The signals transmitted to central control must pass along the gallery, filled with high-power modulators. The transmission system must have a high immunity to radiofrequency interference (RFI) and, considering the distances involved, to cross-talk. Coaxial cables or individually shielded pairs are extravagant; twisted pairs, with balanced circuits where practical, were chosen for transmitting all but video signals. Voice communications and "high-level" signals, greater than 10-V peak, are transmitted in separate cables from the low-level signals. In general, circuit impedances are low, 1000 ohms or less. Both in monitor and control circuits, relays are preferred to solid-state circuits, when suitable, not only because of lower cost but also for their greater tolerance to momentary overloads.

Multiple beam operation of the accelerator yields beams of different currents and energies, interlaced in some complicated pattern. An adequate beam monitoring system must do better than averaging the characteristics of all beams; it must measure the characteristics of each beam independently. This is accomplished by measuring the parameters (current and position profiles along the accelerator) of each beam pulse and by arranging the display so that each beam may be examined independently.

**CENTRAL CONTROL.** Central control contains controls and displays for all thirty sectors, trigger programming equipment, radiation monitor readouts, and display and control panels for specialized equipment such as the master trigger generators, the master oscillator and main booster, and water-cooling towers. The operations console contains injection controls, beam monitoring displays, beam guidance controls, a panel which can be switched to display status and analog signals and to operate controls in any one sector at a time, and summary indications to alert the operator as to which sector is likely to contain the source of trouble when he cannot obtain a beam.

**DATA ASSEMBLY BUILDING.** The control room in the Data Assembly Building operates the switchyard magnets, monitors all interlocks in the switchyard, and has complete information about the beam from the end of the accelerator

through the beam switchyard and target areas to the ultimate beam dump. It is manned continuously during operation. It is described in detail in Chapter 19.

**LOCAL CONTROL AREAS.** In general, complete local control and monitoring exists for ease of maintenance of all equipment. Only those operational adjustments which are expected to require attention from day to day are duplicated in central control.

The alignment system is controlled from the alignment observation room at the end of the accelerator housing behind the injector. The wiring for this system is separate from the controls for the rest of the accelerator. Alignment is, in principle, an off-line process; there is no need for central control to be involved.

A complete console for operation of the injector, 40 ft of accelerator, and the first beam-analyzing station (BAS 1) is located in the injector area. For the first 2 months of operation, the injector console was manned. Since that time, the injector has been operated satisfactorily from central control, and the injector console has been visited only at the beginning and end of shutdown periods of a weekend or more.

An I & C alcove in each sector serves as a data assembly point for all signals to and from central control. Local interlock logic and automatic control equipment are also located in the alcove. All signals to and from central control can be monitored and tested, and it is possible to operate the entire sector from the alcove. Initial tests of the accelerator were made using the injector, Sectors 1 and 2, and a temporary beam-analyzing station located at the beginning of Sector 3. The Sector 2 I & C alcove served as temporary "central control" for these tests.

The I & C alcove in Sector 11 has been fitted with a console for control of the positron source and of special beam guidance equipment in the next four sectors. Once some operational experience has been gained, the necessary signals will be transmitted to central control; the Sector 11 console will thereafter, like the injector console, be manned only for troubleshooting during major shutdown.

#### *Analysis of control requirements (KEB)*

The signals required for beam operation were determined after an extensive study of the anticipated operational and control problems of the accelerator. The development of basic concepts will be outlined briefly, in order to explain the selection of particular signals. The study was not restricted to the accelerator control problems alone but included consideration of relations with all other areas which might affect the layout of the control system. Such areas were the experimental physics work, maintenance, data collection of component performance, and others. These interrelationships had to be understood so that the control system could meet their demands.

It was natural that operational experience with the Stanford Mark III accelerator should be used as a guide in these initial studies.

**OPERATIONAL CONCEPTS.** The guidelines given for the development of the control system stated that beam operation was planned to be continuous with infrequent scheduled shutdowns and that all operational controls for the accelerator should be directed from one place, known as the Central Control Room (CCR). Local operations were to be on a temporary basis only.

The concept of continuous beam operation required that maintenance and repair of critical components (mostly electronic) be possible while the beam was on. As a consequence, such equipment was not to be installed in high-radiation areas which would not be accessible during operation. In the klystron area, the radiation level was to be kept low enough so that maintenance personnel could be present during operation.

A further consequence of these concepts was the specification that all equipment contributing to beam operation should operate unattended and with proper self-protecting features. However, the idea of continuous unattended operation was not inconsistent with the assumption that such equipment would initially be started up and adjusted locally.

The close relationships between operating a beam and performing maintenance and repair on components along the machine made it necessary to postulate a "maintenance" center in the control room, so that these activities could be coordinated most efficiently.

With the development of these concepts, ideas on the communication system between the CCR and the accelerator equipment began to take shape. After a detailed study of the cost involved in transmitting data from the accelerator to CCR, it was decided to divide the accelerator into thirty sectors, each 333 ft long. In each sector, data would be collected at the I & C alcove and transmitted to CCR. The sector concept was applied to the main injector, which became known as Sector 0, and also to the beam switchyard. Initially, the concept included means for local operation. This idea was dropped later when the control requirements were understood better. Although the I & C alcove is primarily a data collection point, it provides a full display of sector status signals and allows access to analog and control signals for analyzing the system performance.

**BEAM CONTROL CONCEPTS.** Major factors in beam operation include energy control, phase control, and beam guidance. Some fundamental decisions had to be made regarding the methods and layout of these controls. Regarding energy control, it was decided that a variable voltage substation (VVS) with a circuit breaker on the secondary should be placed in every second sector, with the ac output distributed to the modulators in the two sectors. This scheme provides continuous energy control over the operating range of the klystrons.

The basic concept also provides for control over the energy contribution of a single klystron. This is achieved by the use of two trigger signals at each

modulator. The first, or "accelerate," trigger operates the modulator so that the klystron RF output contributes to the beam energy. The second, or "standby," trigger is sufficiently delayed so that the klystron RF pulse does not contribute to beam energy. The RF energy in a standby pulse is entirely dissipated in the disk-loaded waveguide and its termination. It serves to maintain the waveguide temperature and the VVS load and is also used for phasing and maintenance purposes.

With respect to phasing, it was recognized that individual, remote phase-control of each klystron using energy maximization as the phasing criterion was unworkable. An automatic phasing system was conceived that could phase the klystron with respect to the electron bunches in the beam. The formalization of this system was strongly influenced by requirements of the centralized control system. The phasing system is described in Chapter 12.

Beam guidance did not offer any particular problems with regard to centralized control. It had straightforward sector-by-sector control and dc analog requirements. The beam monitoring problem, however, was more complex. It had to provide beam position and intensity information per sector with simultaneous display at CCR. The system finally adopted provides for two types of signals from each sector. One signal contains the logarithm of the beam pulse charge  $Q$  together with the horizontal and vertical displacements of the beam. The other contains a signal linearly proportional to the charge of the pulse. Both signals have bandwidth small enough to be transmitted to CCR on a normal telephone-type wire pair. The information from all sectors is displayed on four scopes: one each for horizontal ( $X$ ) displacement, vertical ( $Y$ ) displacement,  $\log Q$ , and linear  $Q$ .

The necessity of keeping variations of the principal operating parameters within permissible limits was also recognized. Analysis of the effect of klystron beam voltage variations led to the requirement for individual de- $Q$ 'ing circuits in each modulator so that the necessary pulse-to-pulse amplitude stability could be achieved. These circuits are described in Chapter 13.

The temperatures of the disk-loaded waveguide and waveguide drive line systems are kept within acceptable limits by automatic control of the cooling-water temperature. The cooling-water system is described in Chapter 24.

**INTERLOCKS.** All equipment subsystems along the accelerator were examined for susceptibility to damage caused by failure or malfunction of other subsystems. This work resulted in the specification of protection systems. Examples are the machine protection system (MPS) and the modulator-klystron package (M-K package). The MPS shuts off the beam to protect components in the beam line, such as accidentally closed vacuum valves, and to protect beam scrapers or the disk-loaded waveguide against severe mis-steering of the beam in case of a degaussing power supply failure. The beam switchyard is protected from beam energy changes which fall outside the acceptance band. Such changes in energy result from failures of equipment controlling the energy contributions of eight or more klystrons. The MPS, thus, monitors the operation

of the vacuum system, cooling-water systems, RF drive system, and the ac voltage system and shuts off the beam when system components are endangered. The M-K package is described below. The MPS is described in Chapter 21.

The personnel protection system (PPS), like the MPS, extends over the whole accelerator. Its requirements state simply that access to the housing shall be possible only when all variable voltage substations and the injector are off, i.e., there is no RF power and no beam. The system has strong ties with the control system. The PPS is also described in Chapter 21.

**CRITERIA FOR THE SIGNAL SELECTION.** The development of the equipment layout in the accelerator and of the basic control concepts for establishing a beam resulted in a number of well-defined subsystems with specified performance and protection features. The actual selection of the signals used in operating the accelerator from CCR was based on this layout. The large number of signals involved and the cost of obtaining, transmitting, and displaying them made it mandatory to select critically and to handle only the minimum necessary for efficient operation.

The first set of signals was obtained by listing the basic operational steps to obtain a beam. This analysis selected the control and analog signals necessary to obtain voltage, current, and related adjustments. These signals were supplemented by status signals which would indicate that a piece of equipment had been turned on locally and was available for operational control. The resulting set of signals was designed to permit the operator to set the essential beam parameters and to steer and monitor the beam. Any piece of equipment contributing to the beam and failing during operation could be located by sector and type via the change in its status signal. The cause of the trouble would have to be identified at the location of the equipment in question. This concept eliminated a lot of secondary information which would be of limited use at CCR.

The problem of monitoring in-tolerance operation of the various subsystems proved to be more complex. The objective was to obtain the status of the most significant characteristics at acceptable cost. This was possible for temperature-controlled systems and the master oscillator output power limits. In other cases, a sufficiently accurate analog signal was obtained, such as the frequency of the master oscillator. No easy solution appeared to be possible for the important information on klystron output pulse amplitude and phase stability. A system that could transmit all relevant information with the accuracy deemed necessary was found economically unreasonable. For this reason, a scheduled local monitoring procedure was assumed, to supplement the subsystem performance monitoring from CCR.

**STANDARDIZATION OF SIGNALS.** Concurrent with the evaluation of the operational signals, the means for transmitting these signals to CCR were defined. Status signals were to be transmitted via a time division multiplex system, and analog and control signals via hard wire. The I & C alcove in each sector

was planned to accommodate the necessary terminal equipment and a 24-V battery to supply power to the signal circuits.

In order to standardize the signal sources, the following arrangements were made with the designer of each piece of equipment. For status signals, a contact closure with ungrounded contacts was to be provided to indicate the proper operating state. A 1-kohm source providing a 0–5-V signal analog of the quantity to be measured or a 1-kohm potentiometer was specified for analog signals. For on-off or up-down control, a floating bipolar latching relay or two separate relays with diode steering for momentary bipolar control were required.

A different technique was adopted for the control of the dc steering power supplies. These were equipped with stepping motors controlled directly from CCR.

**SIGNALS AVAILABLE AT CCR.** The transmission capacity for the data flow to and from each sector was specified to provide for 100 status, 20 analog, and 24 control signals. The simultaneous display at CCR of all these signals from thirty sectors would have been rather costly. An analysis of operational needs indicated that not all of these signals had to be available simultaneously. The key to the solution was in the fact that the signals in the sectors are repetitive. It was, therefore, decided to locate all status, analog, and control signals from one sector on a panel with selector switches so that it could be connected to any of the thirty sectors. Three such panels were made available. In order to warn of changes in a sector not connected to any of these panels, two additional alarm signals were provided from each sector, i.e.,  $2 \times 30$  sets. One signal indicates that the beam has been shut off from a sector by the MPS; the other signal warns of an out-of-tolerance operation that needs attention. The sources of the alarms can be identified when the panel is switched to the sector so indicated.

The switched sector panel is of greatest use during initial adjustments or when the beam is off. After the beam is established, interest is focused on the subsystems that are needed for maintaining the beam, the most important being beam steering and monitoring. Speed of action requires that controls and information from such systems be available continuously.

The essential status of the klystrons in each sector and important information about the PPS are also displayed continuously.

Signals for control of the injector and the beam switchyard are all “one of a kind” and are displayed continuously on separate panels.

Signal and controls made available at CCR from the above concept proved to be adequate and useful when beam operation started. During the first 8 months of operation, energy control was accomplished only by changing the number of klystrons in use. At the end of 8 months, the only major changes were that a vernier control of energy, based on adjustment of the RF phase of pairs of klystrons, was being installed; a limited video system was being connected to allow CCR viewing of the RF pulse envelope for each klystron.

## 15-2 Modulator-klystron logic (KEB)

Concurrent with the formulation of the energy control concept, as applied to the 240 accelerator klystrons, an analysis was made to determine what information from the klystron modulators had to be sent to CCR to operate the machine effectively.

The particular subject of this section is the problem of the remote and local control requirements converging at each klystron and modulator and the integration of the fault protection and recycling concepts. The resulting solutions provided a control circuit for each klystron modulator, the M-K package, and a control circuit for all klystrons in one sector. The latter determines the mode of operation either of individual klystrons or of all the klystrons of the sector. It was called the "modulator trigger mode switch control logic" (MTMSCL) to the bewilderment of the uninitiated.

Before going into details of these circuits, the method used for controlling energy and evaluation of the operational information from each modulator-klystron will be described.

### *The basic energy control concept*

**VVS CONTROL.** As mentioned above, a VVS is installed in every second sector, supplying the operating voltage to the klystron modulators in two sectors. In each of the fifteen sector pairs, it is necessary to remove or to add the energy contribution of individual klystrons. This arrangement defines the scope of the basic energy control. It provides for continuous VVS control over the operating range, complete disconnection of the VVS output, and individual klystron "on-off" control.

The operational concept requires that all klystron-modulator units be turned on and initial adjustments be made locally and that thereafter all controls for beam operation be exercised from central control.

Another control requirement was added, resulting from the de- $Q$ 'ing circuit which maintains the klystron pulse-to-pulse output stability within specified limits. This requirement was that the de- $Q$ 'ing level should follow the modulator operating level to keep the power dissipation in this circuit within tolerable limits.

The layout which provides for mutual tracking of the VVS output and the de- $Q$ 'ing level utilizes an adjustable dc reference source. The VVS control circuit regulates the ac output to match this reference. The same dc reference is also fed to the modulators in the two sectors and is used as the de- $Q$ 'ing reference. Small corrective adjustments for ac input and de- $Q$ 'ing level are provided at each modulator to take care of individual circuit variations and to insure uniform operation.

This control scheme was analyzed in great detail with respect to its suitability for remote operation and reliability. One point of concern was the



possibility of failure of the reference, thus removing the de- $Q$ 'ing voltage, which could cause substantial damage to the de- $Q$ 'ing circuits. In order to offset this possibility, a unit called the "monitor rectifier" was connected to each dc reference source. Its purpose is to monitor the source and to provide the necessary de- $Q$ 'ing level in case the source should fail. In order to match the established de- $Q$ 'ing level, this rectifier is fed from the actual VVS output voltage. Its output is set somewhat below the reference voltage to avoid interference with normal operating conditions. If the reference voltage source fails, the monitor rectifier thus causes the VVS to regulate its output to the lowest level.

**THE INDIVIDUAL KLYSTRON CONTROL.** The need to change the beam energy in each sector by an amount corresponding to the contribution of a klystron is resolved by the "accelerate-standby" concept. It simply provides accelerate and standby triggers for each modulator. With the accelerate trigger selected, the klystron RF power adds energy to an electron beam present in the accelerator waveguide. In the standby mode, the trigger is sufficiently delayed so that the RF power does not contribute to the beam energy. This concept maintains the thermal equilibrium in modulator, klystron, and attached waveguides and is fast enough to change mode of operation from pulse to pulse. It serves as a basic feature in multiple beam operation, recycling of modulators under faults, klystron phasing, and other applications.

#### *Klystron-modulator information for Central Control Room*

The selection of these signals was largely based on economic considerations. Any signal proposed was carefully analyzed with respect to the "need to know," the cost of obtaining, transmitting, and displaying it at CCR. It was recognized that, for operation, it is sufficient to know that the modulator-klystron is "on" or "off" and, when on, that it is operating within specification. The on-off requirement is fully satisfied by three status signals from each unit.

The three status signals selected from each klystron-modulator unit have the following information content:

1. "Modulator available" (Mod available) indicates that the local startup is completed, all interlocks are closed, and filaments are turned on. The unit is ready for operational control from CCR, such as turning on and setting the klystron voltage and applying the trigger. When this signal changes state, it indicates that the respective unit is not available for operational control. This can be due to a fault that shut off the modulator or because maintenance work is being performed on the modulator. Details of faults are not given to CCR and have to be identified from the information at the unit.

2. When the klystron voltage is set, the trigger can be applied to the units in a sector. When this is done, the average klystron current is monitored and a signal "modulator on" (Mod on) is transmitted to CCR from each unit. This signal was selected to confirm that the modulator trigger has become effective, because the generation of RF output power is delayed until an attenuator in the drive input is removed, which takes several seconds and serves to protect the klystron output window.
3. The final signal selected reads "RF OK" and indicates the attenuator is fully removed and that a preset value of RF output power has been exceeded. The unit is now fully operational; it can be operated in the accelerate or standby mode as defined previously. With the set of signals, "Mod available, Mod on, RF OK," the essential operating states of the klystron-modulator unit can be identified from CCR.

Proper performance can be monitored best by looking at the RF output waveform of the klystron. A system that could transmit to CCR all the pulse information considered necessary was at first found to be too costly. For the same reason, the idea of monitoring the RF signal locally and transmitting a status signal about its shape could not be realized. In order to get the necessary information to CCR, the concept of local turn-on and tune-up was extended to include scheduled monitoring. This monitoring routine was to be an integral part of operation.

#### *Modulator-klystron protection (M-K logic)*

The operational requirements of the klystrons and modulators involve local start-up and initial adjustments, local monitoring of performance and fault diagnostics, self-protection, accelerate-standby control, and derivation of three status signals from each unit.

A special rack was added at each modulator-klystron to accommodate the equipment resulting from these requirements, such as klystron output monitoring, drive-line controls, vacuum gauge power supplies, and fault protection. The specifications for these items were determined by the need to integrate the operational and fault protection requirements of the klystron. The two key items were the M-K logic and the accelerate-standby mode control.

The major development was focused on the protection of the pulse transformer, the klystron proper, and its waveguide window. Experience has shown that klystron window life can be prolonged when the RF output is gradually increased during start-up, which can be achieved by slowly removing a protection attenuator in the input drive line. Furthermore, unfavorable operating conditions on the load side of the window should be avoided, such as poor vacuum or reflected energy due to arcing in the waveguide.

For klystron protection, safety limits were set for the beam voltage measured at the cathode and the current into the pulse transformer.

The criteria for the operation of the protection attenuator specify that full attenuation shall become effective every time the klystron RF output

disappears for more than a few seconds. Removal of attenuation is initiated when RF drive power exists at the klystron input and the modulator has started pulsing the klystron.

Modulator operation, in turn, is interlocked with the protection requirements for the klystron. When these conditions are met, modulator-klystron operation may start and the attenuator is removed. If, during operation, any of the interlocks in the modulator open, pulsing stops, and the drive input power is attenuated.

The protection concept discontinues operation temporarily in case of a fault and resumes operation automatically when safe operational conditions for the klystron are restored. Some fault conditions in the modulator are handled by this fault protection cycle.

When a preset number of such faults is exceeded in a given time interval, modulator operation is discontinued. Such an event is indicated to CCR by the "modulator not available" signal. Fault tracing and restarting has to be done locally.

The signals monitoring the safe operation of the klystron act upon a switch controlling the trigger to the modulator. The sequence of operations in this trigger control and the signals acting are as follows: Fault signals from the klystron, i.e., reflected energy, overvoltage, and overcurrent, are compared with a preset threshold signal. When this threshold is exceeded, they act on a gate in the trigger circuit and shut off the trigger. This condition is held for about 1 sec, and the gate is opened again. The trigger can enter the modulator and, if the fault has cleared in the meantime, operation will continue; otherwise, the first klystron pulse will generate a new fault input and again remove the trigger.

The reflected energy fault indication may be followed by an unsatisfactory vacuum condition on the load side of the window. This latter signal will withhold the trigger in a relay circuit until the vacuum improves above a preset value; operation then resumes automatically. A vacuum gauge failure, however, will hold this relay circuit open until the gauge is replaced.

Any of the above fast or slow interlocks will advance the fault counter in the modulator.

The two signals acting in the attenuator control circuit are the "RF drive" and "modulator on" signals. The first is established at the output of the sector drive sub-booster, the second is derived at each modulator. When either one or both signals disappear, attenuation is applied in the drive line. The relay indicating the "modulator on" condition in the attenuator motor control circuit has a delay circuit which keeps it energized for about 2 sec after the "modulator on" signal is removed.

Klystron operation can, therefore, be resumed immediately when fast-acting fault inputs clear within the 1-sec time interval when the trigger is removed. When the fault is repeated at the next pulse or a slow input removes the trigger, the delay time expires and the attenuator is dropped in. Removal of the attenuator prolongs the restarting by about 10 sec.

The above arrangement has proved very successful in coping with fault situations that can be cleared by temporarily suspending operation of klystron or modulator.

#### *Modulator trigger mode switch control logic*

Several criteria are involved in defining when a klystron shall operate in the accelerate or standby mode. The latter mode always applies when a klystron is off and during the turn-on period until the attenuator is fully out, since the RF output pulse of the klystron displays substantial phase variations during this period.

When the attenuator is out, the RF pulse is fully established and either mode can then be selected, depending on the operational objectives. For example, the standby mode must be used while the phasing system samples the beam-induced voltage in the accelerator and the phase of the RF wave. Beam energy adjustments can be made by selecting the appropriate mode. It is also possible to place all klystrons into the accelerate state simultaneously, subject only to the phasing needs.

The mode control is achieved by selecting in the sector trigger generator the accelerate or standby trigger for the modulator in question. One mode control relay is provided for each modulator. These relays are controlled from inputs at the local level and from CCR. All control, monitoring, and logic functions are performed by relays. They are assembled in a special unit (MTMSCL) located in the I & C alcove of each sector. In addition, they provide status input to the transmission system to central control.

The operating state of each modulator is monitored from its status signals. The operating state of the klystron determines when the mode switch can be set to accelerate. This is permitted when the RF OK signal exists, and the operating voltage for the mode relay is made available. The phasing system has standby control only; it cannot set to accelerate. It cancels, however, any individual accelerate control from CCR. The CCR also has standby control. The "all-accelerate" control is common to all modulators in one sector. The phasing system can override this control in order to set a klystron being phased to standby, but the klystron immediately returns to accelerate when phasing is completed.

### **15-3 Beam monitoring system**

An important problem with the SLAC accelerator is to determine accurately the transverse position of the beam within the accelerating structure. Moreover, since multiple beams of widely different charge will be used, it is essential to be able to observe the position of each beam independently.

Sensors are in use which produce video output signals proportional to the horizontal and vertical position coordinates of the beam measured from the

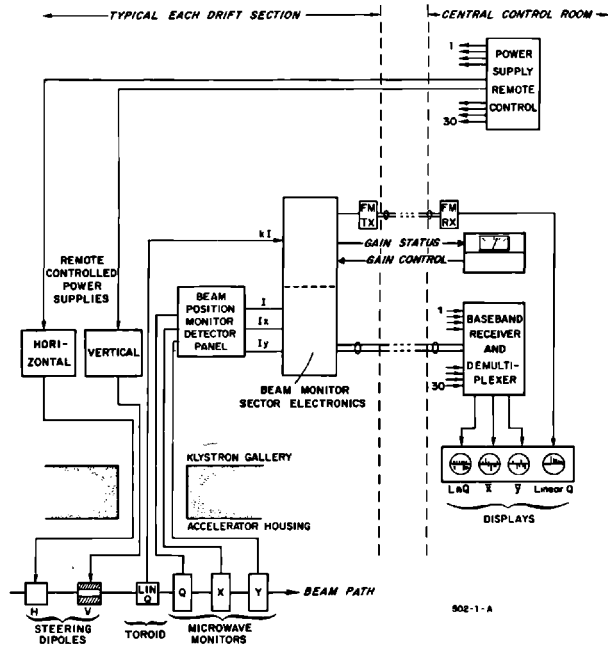

Figure 15-1 Block diagram of beam monitor system.

central axis. In the two-mile SLAC accelerator, however, the transmission of large numbers of such wide-band signals to the control room would be difficult and costly. The approach taken here has been rather to develop a system in which video pulses are processed locally, i.e., at the drift section at the end of each 330-ft sector, to obtain high-level average position signals suitable for transmission over a hard-wire telemetry link.

Figure 15-1 illustrates the main components of the beam monitoring system located at a drift section in the SLAC accelerator, and the connections to the CCR. Three microwave resonant cavities provide RF outputs which are functions of beam intensity ( $I$ ), intensity times horizontal displacement from the accelerator central axis ( $I_x$ ), and intensity times vertical displacement ( $I_y$ ). These are fed to microwave detector circuitry which produces video outputs directly proportional to  $I$ ,  $I_x$ , and  $I_y$ . These signals are processed by the beam monitor sector electronics unit to give  $\ln Q$ ,  $x$ , and  $y$  in a serial form, where  $Q$  is the total charge in the pulse. This signal is sent by a baseband telemetry system to a demultiplexer at the CCR, together with similar signals from the remaining twenty-nine sectors.

The demultiplexer first samples each of the thirty signals and channels  $\ln Q$ ,  $x$ , and  $y$  into three separate oscilloscope displays. A remote control system allows the operator to adjust the steering dipole currents at any sector while monitoring the resulting beam position displacements for the entire machine.

More accurate charge monitoring is accomplished by means of a ferrite toroid through which the beam passes. After processing in the beam monitor sector electronics panel, a signal proportional to total charge in a pulse is sent from each sector to central control by means of a FM transmission system using one wire pair in a fifty-pair telephone cable. At central control, the accurate charge signal from each sector is demodulated, fed to a multiplexer along with similar signals from other sectors, and finally presented on an oscilloscope.

### *Beam monitoring sensors (HAH, EVF, ZDF)*

**MICROWAVE SENSORS.** Initial SLAC requirements called for two designs of beam position monitors. The first was to have an aperture not smaller than the accelerator structure. Monitors of this design were to be installed principally in the drift sections at the end of each of the thirty sectors of the linear machine and to be capable of detecting 0.020-in. horizontal and vertical beam deviations with respect to the machine axis, for beam pulse currents in the range of 1 to 300 mA. A second design was required for position monitors to be installed in the beam switchyard. Performance requirements here were similar to the first design, but the monitor aperture had to be as large as possible.

Much of the early exploratory and design work on the SLAC monitors was done by Brunet *et al.*<sup>1</sup> and Lee.<sup>2</sup> Some of the types of beam sensors

**Figure 15-2 Beam position sensors.**

TYPE OF MONITOR	SCHEMATIC	REMARKS	REFERENCE
SYMMETRICAL MATCHED WAVEGUIDE		LOW SENSITIVITY. DIFFICULT TO CALIBRATE.	15-1
RESONANT WAVEGUIDE RING		GOOD SENSITIVITY. CUMBERSOME STRUCTURE.	15-1
SHORTED WAVEGUIDE		LOW SENSITIVITY. REQUIRES TWO SENSORS PER COORDINATE.	15-1
TM <sub>120</sub> CAVITY		GOOD SENSITIVITY. ZERO OUTPUT WHEN BEAM CENTERED. SMALL SIZE.	15-1
SACLAY LOOPS		VERY LOW SENSITIVITY. COMPACT. 4 LOOPS CAN BE PLACED IN ONE SECTION.	15-3
TM <sub>010</sub> CAVITIES		LOW SENSITIVITY. CAVITIES MUST BE EXACTLY MATCHED.	15-3
DIFFERENTIAL PULSE TRANSFORMER		LOW SENSITIVITY.	15-4

considered are illustrated schematically in Fig. 15-2. They are discussed in the references given.<sup>1,3,4</sup> In spite of greater complexity and cost, microwave monitors were preferred to ferrite-cored differential pulse transformers because much higher sensitivity could be obtained with high- $Q$  resonant cavities. Theoretical and experimental investigation led to the choice of  $TM_{120}$  resonant cavity sensors for the "in-line" monitors to be installed along the linac. It was also decided that the beam aperture in the monitor should be 0.8 in. in diameter.

The resonant waveguide ring was initially chosen for the beam switchyard monitors, but its sensitivity deteriorated rapidly as the beam aperture size was increased. It was found that the  $TM_{120}$  cavities operated well with a 2-in. diameter aperture, so these were used in the switchyard.

Each monitor assembly comprises two orthogonally mounted position cavities and one circular cavity operating in the  $TM_{010}$  mode. The output of the latter cavity is independent of beam position and is used to normalize the position cavity output signals with respect to beam current.

The most important parameters of the in-line and switchyard monitors are given in Table 15-1.

**THEORY AND DESIGN: IN-LINE MONITORS.** The RF-video system is shown in Fig. 15-3. Semirigid coaxial cables with low loss and good phase stability are used to transmit the RF signals from the cavities up to the detector panel in the klystron gallery. Here, the RF signals are converted to video pulses proportional to beam current  $I_0$  and beam current times displacement ( $I_0 x$  and  $I_0 y$ ). The signs of  $I_0 x$  and  $I_0 y$  indicate the displacement directions. The video signals are processed in the sector electronics described below.

**IN-LINE CAVITY DESIGN.** The  $TM_{120}$  cavity is formed from a section of waveguide—broad dimension  $a$ , narrow dimension  $b$ . The guide is closed by shorting planes which are separated by a distance  $d$  (approximately one guide wavelength at the accelerator operating frequency). Circular apertures are placed in the centers of the broad faces to permit passage of the electron beam

**Table 15-1 Parameters of in-line and beam switchyard monitors**

Parameters	In-line monitors		Switchyard $n$
	Reference	Position	Reference
Sensitivity	250 mW/mA <sup>2</sup>	100 $\mu$ W/mA <sup>2</sup> mm <sup>2</sup>	40 mW/mA <sup>2</sup> 4
Loaded $Q$	1200	600	1200
Unloaded $Q$	9000	15,000	5000
Frequency	2856 $\pm$ 0.3 MHz	2856 $\pm$ 0.6 MHz	2856 $\pm$ 0.3 MHz 2
Operating temperature	110°F	110°F	90°F
Temperature detuning	25 kHz/°F	25 kHz/°F	25 kHz/°F

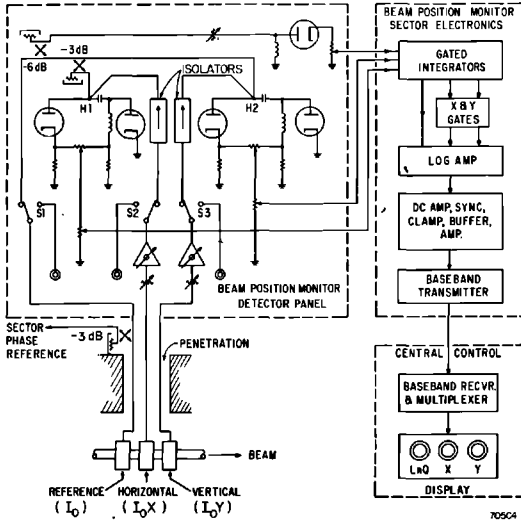

Figure 15-3 In-line beam position monitor system.

(see Figs. 15-2 and 15-4). The beam is tightly bunched at the accelerator frequency.

Power extracted from the beam is given by

$$P_b = \frac{1}{2} \operatorname{Re} \int_{-\infty}^{\infty} E_z I_{RF}^* dz \quad (15-1)$$

where  $E_z$  is the peak value of the electric field along the axis of the electron beam, and  $I_{RF}$  is the peak value of the fundamental frequency component

Figure 15-4 In-line monitor cavity assembly.

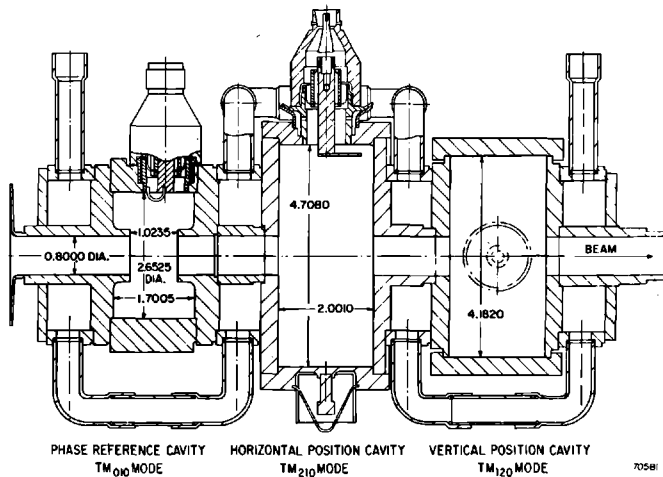



of beam current. Because  $E_z$  and  $I_{RF}$  are in phase, and  $I_{RF}$  is twice the average beam current during the pulse  $I_0$ ,

$$P_b = E_z I_0 b \quad (15-2)$$

$E_z$  is related to  $E_m(y')$ , the maximum electric field in the cavity for a given beam position,  $y'$ , by

$$E_z = E_m(y') \sin \frac{2\pi y}{d} \quad (15-3)$$

$y' = 0$  when the beam axis coincides with the center of the waveguide apertures, and  $E_z$  changes phase by  $\pi$  as the beam crosses the center.

Since the power induced must equal the total dissipated power,  $P_b$  may also be expressed in terms of the loaded shunt resistance,  $R_L$ , of the cavity,

$$P_b = \frac{1}{2R_L} \left[ \int_{-\infty}^{\infty} E_z dz \right]^2 = \frac{[E_m(y')b]^2}{2R_L} \sin^2 \left( \frac{2\pi y}{d} \right) \quad (15-4)$$

so that

$$\frac{R_L}{Q_L} = \frac{E_z^2 b^2 / 2P_b}{2\pi f U / P_b} = \frac{[E_m(y')b]^2}{4\pi f U} \sin^2 \left( \frac{2\pi y}{d} \right) \quad (15-5)$$

where  $Q_L$  is the loaded quality factor,  $f$  is the frequency, and  $U$  is the energy stored in the cavity.

Since

$$U = \frac{\epsilon_0 abd [E_m(y')]^2}{8} \quad (15-6)$$

where  $\epsilon_0$  is the dielectric constant in vacuum, one obtains

$$\frac{R}{Q} = \frac{2b}{\epsilon_0 \pi f a d} \sin^2 \left( \frac{2\pi y}{d} \right) \quad (15-7)$$

The subscripts are dropped because  $R/Q$  is independent of the load.  $P_b$  must equal the sum of the power  $P_0$  coupled out of the cavity and the power  $P_j$  lost in the cavity walls, so that

$$P_0 = \frac{P_b \beta}{1 + \beta} \quad (15-8)$$

where

$$\beta = \frac{P_0}{P_j}$$

Combining Eqs. (15-2), (15-3), (15-4), (15-7), and (15-8) yields

$$P_0 = \frac{4Q_L}{\epsilon_0 \pi f} \cdot \frac{b}{ad} \cdot \left[ \frac{\beta}{1 + \beta} \right] I_0^2 \sin^2 \left( \frac{2\pi y}{d} \right) \quad (15-9)$$

Equation (15-9) has to be corrected for cavity detuning  $\Delta f$ , finite bunch

width  $\alpha$ , electron transit time  $\tau$ , and field variation across the cavity. The corrected output,  $P'_0$ , is

$$P'_0 = \left[ \left( \frac{1}{[1 + (2Q \Delta f/f)]^{1/2}} \right) \left( \frac{\sin \alpha/2}{\alpha/2} \right) \left( \frac{\sin \pi f\tau}{\pi f\tau} \right) \cos \frac{\pi x}{a} \right]^2 P_0 \quad (15-10)$$

A further correction has to be applied for the field perturbation caused by the beam aperture. In the case of the in-line monitors, however, the variation in  $R/Q$  from the sine-squared distribution [Eq. (15-7)] was too small to measure.

The circular re-entrant  $TM_{010}$  cavity used for phase reference and normalization is discussed in detail by Altenmueller and Brunet.<sup>5</sup> The power output from the cavity is calculated in the same way as for the position cavities. One obtains

$$P_0 = 2 \frac{R}{Q} Q_L \left[ \frac{\beta}{1 + \beta} \right] I_0^2 \quad (15-11)$$

The first three correction factors of Eq. (15-10) apply. The cavity is made re-entrant to maximize the product  $[\sin(\pi f\tau)/\pi f\tau]^2 R/Q$ .

**IN-LINE MONITOR DETECTOR PANELS.** A schematic of this unit is included in Fig. 15-3. It can be seen that the  $TM_{010}$  reference cavity signal is divided four ways—part is used as a reference for sector phase stability, part is used for current normalization, and the remainder is divided and used as phase reference in two hybrid rings. The second input arms to these hybrid rings are connected via attenuators and phase shifters to the horizontal and vertical position cavities, as shown. The output signals are detected by coaxial thermionic diodes, which have a linear detection range (index less than 1.15) large enough to monitor beam currents between 1 and 300 mA. The differential video output from a balancing network between each pair of diodes is fed to the beam monitor sector electronics panel. Each network is adjusted to give zero output when the position cavities are disconnected, and each phase shifter is adjusted to maximize the video output (and to select the desired polarity) when a signal is received from a position cavity. In this condition, each hybrid ring is insensitive to small phase changes in the input signals.

**CONSTRUCTION AND INSTALLATION: IN-LINE MONITORS.** Details of the three-cavity assembly are shown in Fig. 15-4. The cavities, internal drift tubes, and water jackets are constructed from OFHC copper. Stainless steel-copper-water interfaces were avoided because of electrolytic erosion. Specified tolerances on resonant frequency and assembly alignment made close dimensional tolerances unavoidable. All dimensions determining cavity size were held to  $\pm 0.0005$  in. for the reference cavities and  $\pm 0.001$  in. for the position cavities. The latter were fabricated from plates rather than being milled out of solid stock. This method was preferred for reasons of economy and avoidance of leakage “pipes” across the cavity walls. All internal cavity surfaces were machined to a 32- $\mu$ in. finish. A total indicated runout up to 0.010 in. was allowed between cavity apertures in a completed assembly.

Details of the coupling probe assemblies can also be seen in Fig. 15-4. The hybrid  $L$ -coupling was used in the position cavities because it afforded a wide range of  $\beta$  adjustment by rotating the probe assembly, without being critically dependent upon the current contact between the probe outer conductor and the cavity wall. A conventional loop coupling proved to be more suitable for the reference cavity. The inner conductors of both probe types pass through coaxial-sleeve ceramic vacuum seals. The probe assemblies are welded to stainless steel cups brazed into the cavity walls. Conical taper sections adapt the position probes to type-N connectors and the reference probes to type-HN connectors.

Each brazed cavity was checked for  $Q_L$  and resonant frequency with standard probes before final braze assembly. Probes selected for that assembly were then inserted and rotated to give the desired  $Q_L$ . Measurements of  $Q$  were made rapidly and accurately using a swept frequency display with double side-band suppressed carrier modulation to provide frequency markers at the 3-dB points on the  $Q$  curve. The probe positions were marked and then the probes were welded in place. For final testing, the complete assembly was evacuated and water at 110°F was circulated around the cavities. The resonant frequency of each cavity was adjusted by distorting a specially weakened area of one wall (shown on the middle cavity in Fig. 15-4).

After final testing, each monitor assembly was clamped in an aluminum support bracket and attached by adjustable bolts to an accelerator drift section.

In each installation, the support bracket is aligned by optical tooling apertures with the drift section support girder, which contains a Fresnel zone plate for alignment with a laser beam. The rms misalignment between the electrical center of the position cavities and the theoretical beam axis is 0.010 in.

**BEAM SWITCHYARD MONITORS.** Beam position monitors are located at six places in the switchyard. Microwave signals from each cavity assembly are transmitted via semirigid coaxial cables to a detector chassis mounted nearby and shielded from direct radiation. Polystyrene dielectric is used in the coaxial cables and as much as possible elsewhere in each installation, to minimize susceptibility to radiation damage. Video signals from the detector chassis are transmitted to the Data Assembly Building (DAB), where they are processed and displayed (see Fig. 15-5).

**SWITCHYARD CAVITY DESIGN.** The theory of operation is the same as for the in-line monitors. The 2-in. diameter beam aperture reduces the slope of  $E_z$  versus position at the center, and increases field penetration from each cavity into the connecting drift tubes. For the latter reason, drift tube lengths had to be increased to 4 in. to avoid cross-coupling.

**BSY BEAM POSITION MONITOR DETECTOR CHASSIS DESIGN.** This chassis is similar to the in-line detector panel discussed above, with the following exceptions: (1) the signal from the  $TM_{010}$  cavity is used only for amplitude and phase

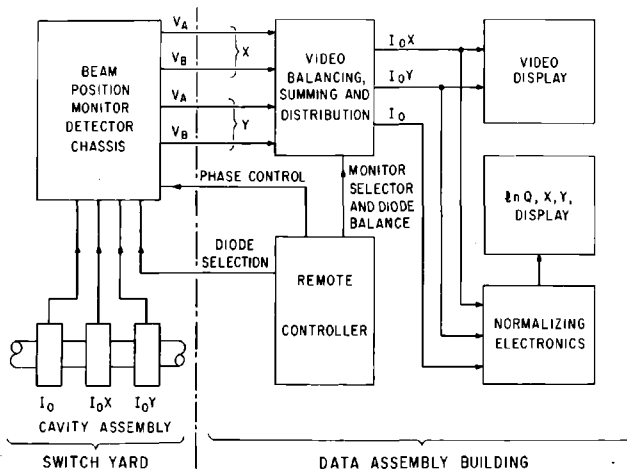

**Figure 15-5** Switchyard beam position monitor system.

reference at the hybrid rings, and not separately detected for normalization; (2) the hybrid ring outputs can be remotely switched either to coaxial thermionic diode detection or to tunnel diode detectors (tunnel diodes are used for low-level detection, and are chosen primarily because their radiation resistance is better than that of other semiconductor devices); (3) the diode video outputs are transmitted directly to DAB; and (4) the phase shifters are motor-driven and remotely controlled.

Equations (15-9) and (15-11) may be rewritten, for small beam displacements,

$$P_p = K_p I_0^2 p^2 \quad (15-12)$$

and

$$P_r = K_r I_0^2 \quad (15-13)$$

where  $P_r$  is the power from the reference cavity at one input to a hybrid ring, and  $P_p$  is the power from one position cavity (either horizontal or vertical) at the second input to the hybrid ring. In this section, all  $K$ 's are constants;  $p$  is the beam displacement, horizontal or vertical. The phase shifters are adjusted so that the two input signals at each hybrid ring are in phase for beam displacements up and to the right. This condition allows the signal powers at the two output ports of one hybrid ring to be written

$$P_A = \frac{P_r}{2} \left[ 1 + \left( \frac{P_p}{P_r} \right)^{1/2} \right]^2 = u^2(1 + v)^2 \quad (15-14)$$

and

$$P_B = \frac{P_r}{2} \left[ 1 - \left( \frac{P_p}{P_r} \right)^{1/2} \right]^2 = u^2(1 - v)^2 \quad (15-15)$$

$P_A$  and  $P_B$  are detected by diodes of which the output voltages are given by  $V_A = K_A(P_A)^{n/2}$  and  $V_B = K_B(P_B)^{n'/2}$ , i.e., the diodes have different conversion efficiencies and different laws of detection. Three quantities are of interest: the difference voltage  $V_D = V_A - V_B$ , the sum voltage  $V_S = V_A + V_B$ , and the normalized voltage  $V_N = V_D/V_S$ . Using the above equations and  $K = K_B u^{n'}/K_A u^n$ , one obtains for  $(n-1)v/2 \ll 1$  and  $(n'-1)v/2 \ll 1$ ,

$$V_D = K_A u^n [(1-K) + v(n + Kn')] \quad (15-16)$$

and

$$V_S = K_A u^n [(1+K) + v(n - Kn')] \quad (15-17)$$

Note that  $V_N$  formed from Eqs. (15-16) and (15-17) is a slowly varying function of  $K$ . If, however, the normalizing voltage  $V_C = K_C(P_r)^{n'/2}$  is derived from a separate diode, then  $V_N$  will change much more rapidly with varying diode characteristics. If the diodes are balanced ( $K = 1$ ) and matched ( $n = n'$ ), then Eqs. (15-16) and (15-17) simplify to

$$V_D = 2K_A n v u^n = K_D I_0^n P \quad (15-18)$$

and

$$V_S = 2K_A u^n = K_S I_0^n \quad (15-19)$$

hence

$$V_N = K_N p \quad (15-20)$$

If the diodes are unbalanced, the position error  $p_e$  (i.e., the distance by which the beam is displaced when the monitor indicates that it is centered) is easily calculated by equating Eq. (15-16) to zero, giving  $v(n + Kn') = K - 1$ , or

$$p_e = \left[ \frac{K-1}{n + Kn'} \right] \left[ \frac{K_r}{K_p} \right]^{1/2} \quad (15-21)$$

Referring to Eqs. (15-12) and (15-13),  $[K_r/K_p]^{1/2}$  is that value of  $p$  for which  $P_p = P_r$  at a given current. For the switchyard monitors,  $[K_r/K_p]^{1/2}$  is found to be 20 mm. Assuming both diodes are linear (the worst case), this means that the unbalance ratio must not be greater than 1.1/1 if  $p_e$  is to be kept below 1 mm.

In the switchyard, the position monitors are used primarily as beam-centering devices, so it is sufficient to display  $V_D$  on an oscilloscope. However, provision exists for forming  $V_S$  and  $V_N$  and displaying  $\ln Q$ ,  $x$ , and  $y$ .

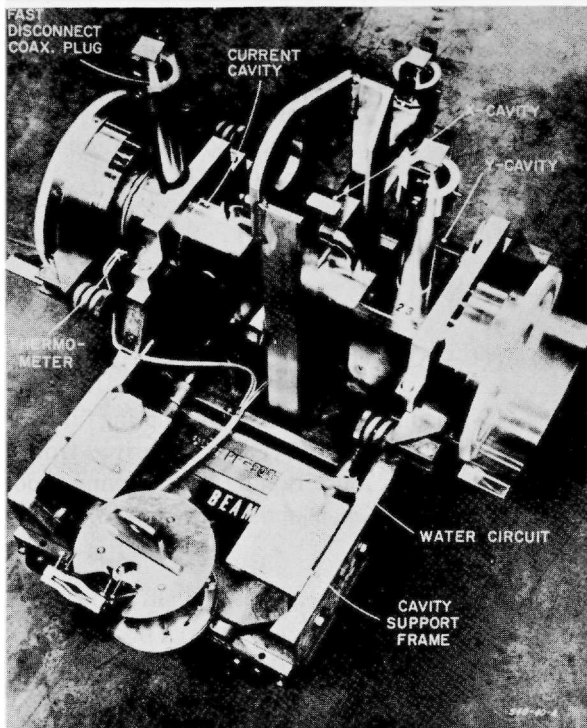

**Figure 15-6** Switchyard position monitor.

**CONSTRUCTION AND INSTALLATION: SWITCHYARD MONITORS.** Construction of the switchyard cavities is very similar to the in-line cavities. Specially developed RF connectors and vacuum seals are used, so that the cavity assemblies can be quickly disconnected and removed by means of remote-handling tools. The support and alignment system is also modified to permit quick removal. A completed monitor is shown in Fig. 15-6.

**OPERATIONAL RESULTS.** The two position monitor systems described above perform in accordance with initial design concepts and are invaluable aids to establishing and maintaining electron beams through the long machine. No troubles have been experienced with the RF cavities. Some inconvenience is caused by imperfect matching of the coaxial thermionic diodes used for video detection. In Eq. (15-16),  $K$  is a function of RF power, so that even if the diode outputs are balanced at one power level, making  $V_D = 0$  for  $v = 0$ , then  $K$  differs slightly from unity at other power levels. This gives rise to a spurious position error signal, as has been discussed.  $K$  also changes with time, as the diodes age. The problem is of no consequence in the switchyard monitors, as a remote balancing control is included in the system. However, in the in-line monitors, it has proved necessary to add a control which enables all RF

position signals to be disconnected from the hybrid rings. The CCR display then shows the zero errors for each monitor at a given time and beam current. In addition, motor-driven balancing potentiometers have been installed in each beam position monitor detector panel. The CCR control which disconnects all RF position signals also switches all control signals from the steering power supply control motors to balancing potentiometer motors. The steering controls in CCR can then be used to balance all diode pairs along the machine at a particular current. Zero errors are thus eliminated, and the operator can steer to a straight display line.

**EXPERIMENTAL END-STATION MONITOR.** A very large aperture, high-sensitivity monitor has been built for measuring horizontal displacements in SLAC end stations. The system is illustrated in Fig. 15-7. The beam sensor is a 3-in. diameter drift tube brazed into the broad walls of S-band waveguide. Common walls are removed to permit beam passage and electromagnetic coupling. The two beam-induced waves travel around the waveguide arms and are combined in a hybrid tee, accurately positioned so that the output signals are equal for a centered beam. The RF signals are converted to 120-MHz IF, logarithmically amplified, detected, and differentially displaced on an oscilloscope. It can be shown that the output for a displacement  $x$  is

$$V(x) = 20S \log \tan \left[ \frac{2\pi x}{\lambda_g} + \frac{\pi}{4} \right]$$

where  $\lambda_g$  is the guide wavelength and  $S$  is the slope of the logarithmic amplifiers in volts per decibel.

The power flow in each arm of the waveguide was measured as  $10 \mu\text{W}/\text{mA}^2$ . A 0.004-in. change in position of a 0.01-mA beam pulse could be detected. It is known that greater sensitivity can be achieved at the cost of electrical aperture size by introducing symmetrical reflections in the waveguide arms. This increases the slope of phase versus position near the center of the monitor.

**Figure 15-7** End-station beam position monitor system.

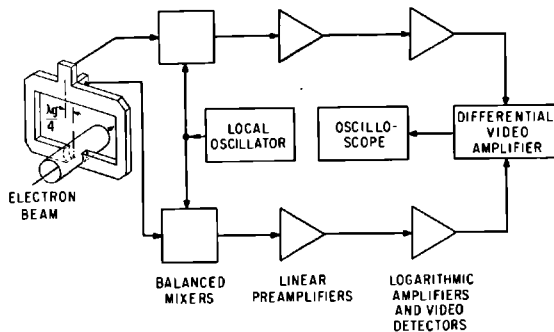

Early tests indicated a response time of 50 nsec, but a long trailing edge appeared on the position pulse after the monitor was installed in one end station. The trouble was traced to a resonance in the drift tube. It was cured on cold test by inserting a narrow ring of lossy material. The inside of the tube has been coated with lossy iron alloy, but at the time of writing the monitor has not been retested in the beam line.

### *Beam monitor sector electronic (RSL)*

The sector electronics unit<sup>6,7</sup> performs two functions: (1) it processes the microwave position monitor video outputs into stretched pulses proportional to average  $x$  displacement, average  $y$  displacement, and the logarithm of charge and (2) it processes the video signal from a toroidal monitor to obtain a 1% accurate measure of beam charge. Both measurements are made at every sector on a pulse-to-pulse basis in order to operate with interlaced beams. Therefore, a measurement must be completed in less than 2.78 msec, with essentially no interference between measurements of successive pulses.

**POSITION MONITORING CIRCUITS.** For a pulse of instantaneous beam current  $I(t)$ , displacement  $x(t)$  and duration  $T$ , the circuit evaluates an average position given by

$$\bar{x} = \frac{\int_0^T Ix \, dt}{\int_0^T I \, dt}$$

To simulate this equation requires separate integration of the two quantities  $Ix(t)$  and  $I(t)$ , followed by division using a logarithmic approximation.

First, the three microwave position monitor pulses are integrated in three separate, gated,  $RC$  integrators followed by field effect transistor (FET), buffer amplifiers, to yield the quantities:

$$\int_0^T I \, dt = Q \quad \int_0^T Ix \, dt = Q\bar{x} \quad \int_0^T Iy \, dt = Q\bar{y}$$

The quantities are held on the integrating capacitors because of the extremely high impedance of the FET buffer and are, therefore, available for the entire interpulse period. The charges are cleared shortly before the arrival of the next beam pulse.

By appropriate gating into a logarithmic amplifier (an operational amplifier with diode feedback), the following circuit operations are performed:

$$\ln(Q + kQ\bar{x}) - \ln Q = \ln(1 + k\bar{x}) \approx k\bar{x}$$

$$\ln(Q + kQ\bar{y}) - \ln Q = \ln(1 + k\bar{y}) \approx k\bar{y}$$

where  $k$  is selected to make  $k\bar{x}$ ,  $k\bar{y} \ll 1$ .



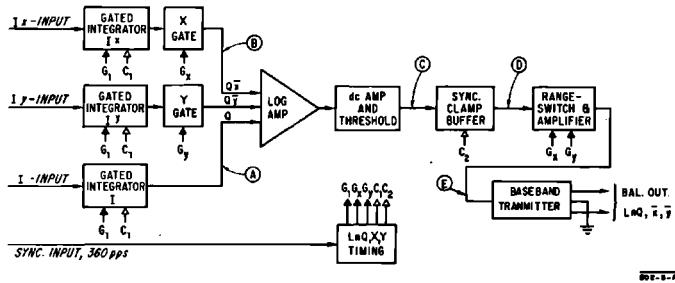

Figure 15-8 Position monitor circuits in beam monitor sector electronics.

The value of  $k$  is easily controlled in the resistive summing network feeding the logarithmic amplifier. The gating is arranged to obtain  $\bar{x}$ ,  $\bar{y}$ , and  $\ln Q$  serially for transmission over a single pair of wires to a demultiplexer in CCR. The basic circuit and its waveforms are shown in Figs. 15-8 and 15-9.

The system can handle a 1000:1 (60-dB) range of signals, from 100 mA 2  $\mu$ sec down to 100  $\mu$ A, 2 $\mu$ sec, or any equivalent charge. The range of position covered is  $\pm 1$  cm; the accuracy of the electronics alone is limited by offsets to  $\pm 0.2$  mm for a 1-mA, 2- $\mu$ sec beam, and degrades to  $\pm 1$  or 2 mm for a 100- $\mu$ A, 2- $\mu$ sec beam. Additional offsets from the microwave diodes degrade the system further.

Because of the logarithmic approximation, the position signals are non-linear at large values. Similarly, because of diode nonlinearities, the  $\ln Q$  measurement is accurate only to about  $\pm 1$  dB over the 60-dB range. Complete details and error analyses are given in the references cited.

CHARGE MONITORING CIRCUITS (LINEAR  $Q$ ). The basic sensor for accurate charge monitoring<sup>7</sup> is a 2-in. o.d. ferrite toroid, through which the beam passes. The 25-turn toroid sends an initial current of  $I_b/25$  into a 95-ohm matched cable, to give an output at the receiving end which represents the instantaneous beam current vs time.

Figure 15-9 Waveforms in beam monitor sector electronics. (See Figure 15-8.)

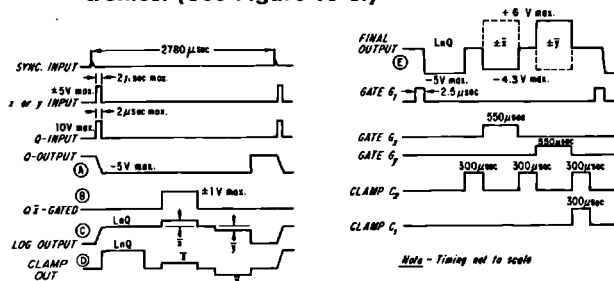

Note - Timing not to scale

The circuit function is to derive a quantity

$$\int_0^T I dt = Q$$

for each beam pulse and to transmit each such signal via FM telemetry to CCR for both oscilloscope and meter display.

Circuit operation is straightforward. The toroid signal is amplified and integrated in a gated, dual *RC*, self-damping integrator. The peak output of the integrator, which is proportional to  $Q$ , is further amplified and then stretched in a sample-and-hold circuit to a full 2.2 msec. The output of the sample-and-hold drives a local FM transmitter.

Gain-switching is provided in the amplifiers, including the preamplifier, to cover a range of 54 dB in 6-dB steps. A 6-dB range of signals can be arranged to lie within the desired 2.5–5-V output range. The gains are switched by the CCR remote control system; a 0–5-V gain status signal is monitored at CCR.

At the bottom of the range, a remote-controlled switch can reverse the input polarity for monitoring positron currents.

The system is calibrated by injecting a known charge of  $5 \times 10^{-8}$  C into a separate 1-turn winding around the toroid. The gating, sample timing, and gain are then adjusted to give the appropriate output. The total system calibration is most easily verified on the CCR monitor in the presence of a beam, by observing the relative outputs of all units for the same nominal input charge.

Complete circuit design details are given in reference 7.

### *Beam monitoring, data transmission and display (KFC)*

The function of the beam monitoring system is to provide the central control operator with a display of beam position and intensity as measured at the injector, each sector, and at several locations in the BSY. The major units of the system at each transmitting location are the beam monitors, the signal conditioning equipment, and the transmitters. At central control, the major units are the receivers, the display electronics, and the oscilloscope and meter displays.

**REMOTE LOCATIONS.** At each measuring location, beam information is obtained from two types of monitors: (1) a ferrite, toroid charge monitor for the precise determination of  $Q$ , and (2) microwave monitors for position ( $x$  and  $y$ ) and intensity normalization. The pulses are conditioned to produce four analog signals on a pulse-to-pulse basis. These are (a) a signal  $Q$  proportional to the total integrated charge (linear  $Q$ ), (b) a signal  $\ln Q$ , proportional to the logarithm of the total integrated charge, (c) and (d) signals  $x$  and  $y$ , proportional to the horizontal and vertical displacement of the beam from the accelerator axis. The linear  $Q$  signal is transmitted as a pulse, 2250  $\mu$ sec long.

The pulse is generated each time a beam pulse passes the current monitor. The transmitter is a stable voltage-controlled, FM oscillator.

The remaining three signals, in  $Q$ ,  $x$ , and  $y$ , are transmitted in serial form, as a return-to-zero, pulse-amplitude-modulated (PAM) wave train. The group of three pulses occupies 2.78 msec and is generated each time a beam pulse passes the microwave monitor.

**TRANSMISSION MEDIUM.** Each remote location transmits information to central control over two pairs of a 50-pair telephone cable. One pair is used for the FM transmission and the other pair is for the PAM wave train. In addition, one pair is required for remote control of the linear  $Q$  amplifier, gain switch, and another pair for analog readback of switch setting.

**CENTRAL CONTROL.** Signals transmitted from the remote locations are received at central control and handled as follows (see Fig. 15-10):

For linear  $Q$  channels, the carrier signal received at central control from each transmitting location is demodulated in an FM receiver. The output pulse waveform is fed to a channel multiplexer which sequentially samples all inputs once in each interpulse period. (See Fig. 15-11 for waveforms.)

The multiplexer output is a serial PAM wave train containing linear  $Q$  information from all remote locations. The output drives an oscilloscope

Figure 15-10 Beam monitoring system, CCR block diagram.

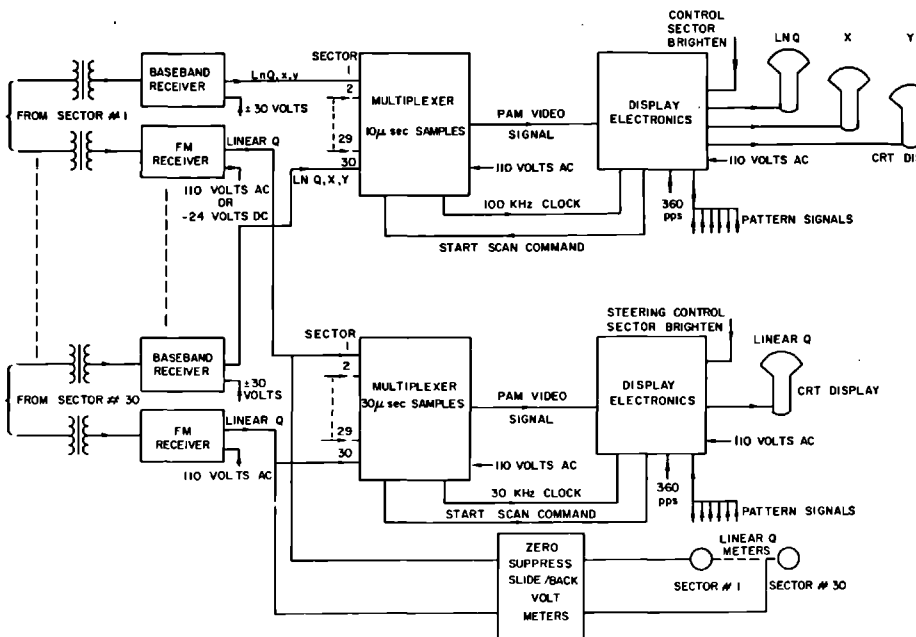

display unit which presents the linear  $Q$  signals in the form of a series of dots. The display unit provides a "scan start" signal to the multiplexer, and, in turn, receives 36 "brightening" pulses from the multiplexer.

Pattern signals from the CCR pattern generator provide appropriate gating waveforms to the display unit for trace displacement when multiple beams are being displayed.

In addition to the oscilloscope display, linear  $Q$  signals are presented on panel meters, one for each remote location. The meter inputs are not gated for selection of a specific beam when running multiple beams.

For  $\ln Q$ ,  $x$ , and  $y$  signals, the PAM wave train from each sector is transformer-coupled from the transmission line to a pulsed clamp which restores the dc level by clamping the waveform to ground during the interval between information pulses. (See Fig. 15-11.)

The clamped waveform is sampled by a multiplexer in a similar manner to the linear  $Q$  system except that the sampling rate is 3 times higher (approximately 100 kHz). Sequential sampling of the  $\ln Q$  signals commences 150  $\mu\text{sec}$  after the 360-pulses/sec master trigger pulse, and it continues for 320  $\mu\text{sec}$ . The  $x$ -position signals are sampled for 320  $\mu\text{sec}$ , starting 1000  $\mu\text{sec}$  after the trigger pulse, and the  $y$ -position signals are sampled for 320  $\mu\text{sec}$  starting 1860  $\mu\text{sec}$  after the trigger pulse. Sampling is initiated by pulses generated in the display unit. Trace brightening pulses at a 100-kHz rate are supplied to the display unit by the multiplexer.

The display equipment consists of three CRT monitors, one each of  $\ln Q$ ,  $x$ , and  $y$ . Provision has been made for display of up to six beams by arranging the traces in different vertical positions on the screen.

**Figure 15-11** Beam monitoring system, CCR waveforms.

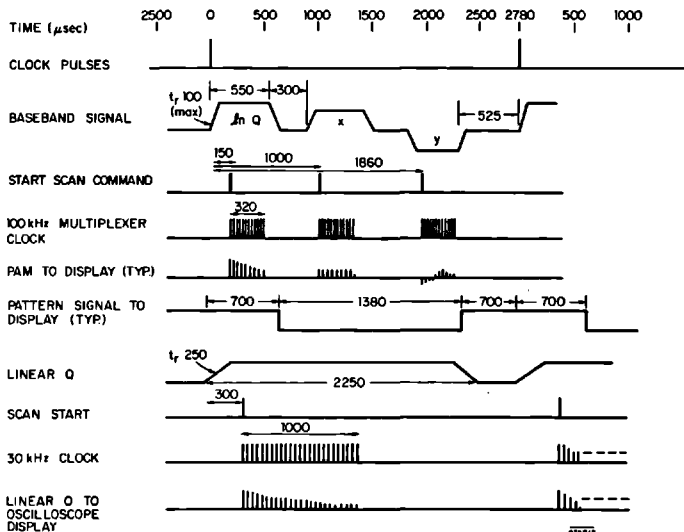

### 15-4 Beam guidance system (LG)

The power supplies and associated controllers required to power the steering dipole magnets, the quadrupole magnets, and the degaussing coils are mounted in the beam monitor rack in the klystron gallery at the end of each sector. This location was chosen to minimize the length of interconnecting wires to the quadrupole and steering dipole magnets which are mounted in the drift section in the accelerator housing below.

Each power supply has a controller which permits adjustment of its output current from either a local or a remote location. The local controls are mounted on the front panel of the controller. Remote control may be exercised either from the I & C alcove or from CCR, except for the degaussing power supply, which can only be controlled from a local position.

#### *Power supplies*

All the beam guidance power supplies are current-regulated, using all-silicon solid-state circuitry. The original beam guidance power supplies were custom-built and were purchased on a performance specification from one manufacturer. A more recent set of high-current quadrupole power supplies are commercially available units, procured to reduce beam breakup by increasing the quadrupole magnet focusing. The ratings of each of the five power supplies are listed in Table 15.2.

**Table 15-2 Comparison of power supply ratings**

<i>Type</i>	<i>Regulated output current</i>		<i>Output voltage</i>	<i>Nominal current regulation</i>
	<i>Min</i>	<i>Max</i>		
Degaussing	1 A	20 A	1.8–44 V dc	±10 mA
Steering dipole	18 mA	18 A	20 mV–20.5 V dc	±0.1% or 5 mA, whichever is greater
Quadrupole	120 mA	7 A	0.45–43.4 V dc	±7 mA
Positron quadrupole	120 mA	14 A	0.45–82.6 V dc	±14 mA
High-current quadrupole	120 mA	15 A	0–60 V dc	±35 mA

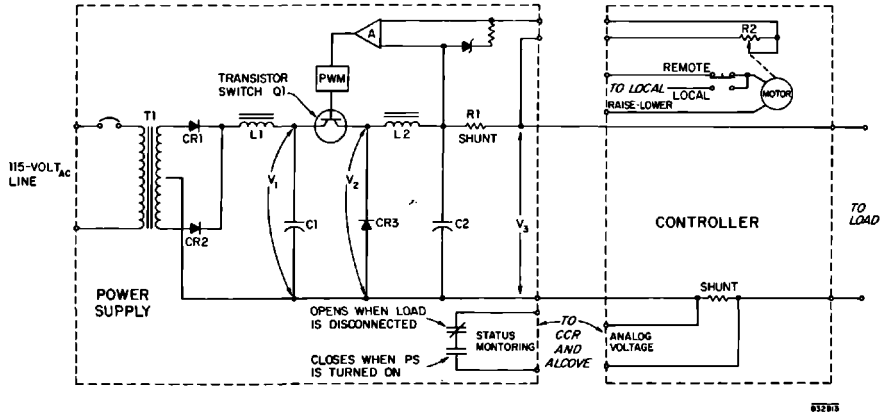

Figure 15-12 Beam guidance power supply and controller.

The degaussing, steering dipole, quadrupole, and positron quadrupole power supplies are current-regulated by pulse width modulation (PWM; see Fig. 15-12). The 115-V ac line is fed to a transformer, full-wave rectifier and LC filter to produce unregulated dc voltage  $V_1$ . Transistor switch  $Q1$  is opened and closed at a rate of approximately 1.5 kHz. The duration of closure determines the magnitude of the output voltage of the power supply. Voltage  $V_2$  appears as a square wave having a constant period and a pulse width directly proportional to the output voltage. Voltage  $V_2$  is smoothed by the LC filter composed of  $L2$  and  $C2$ , and the output voltage  $V_3$  is a dc voltage with a minute amount of ripple modulation. Diode  $CR3$  is a free-wheeling diode that permits current to continue to flow through  $L2$  when transistor switch  $Q1$  is in the "off" position.

Regulation is achieved by sampling the output current through shunt  $R1$  and comparing the voltage across  $R1$  with a reference voltage set by current control potentiometer  $R2$ . The difference between the two voltages is amplified by differential amplifier  $A$  and its output is fed into pulse width modulator  $PWM$  which drives the series transistor switch to the "on" position for a time directly proportional to the magnitude of the desired output current. The described negative feedback circuitry produces an output current which is almost completely dependent on the value of the set resistance of potentiometer  $R2$ .

The power supplies have been used with moderate success in the gallery. Difficulty was experienced by the manufacturer in meeting the overall current regulation specification listed in Table 15-2, and the regulation of the average power supply is approximately a factor of 2 times the values listed in the table. Overall current regulation was specified as the envelope within which the output current had to remain when subjected to either one or all of the following conditions: (a)  $\pm 10\%$  change in line voltage; (b)  $\pm 10\%$  change in load resistance; and (c)  $\pm 20^\circ\text{C}$  change in ambient temperature.

The only problem area remaining at the present time is the occasional loss of power transistors used in transistor switch Q1 in Fig. 15-12.

The high-current quadrupole power supply is a commercially available unit using a Class A series regulator and a silicon controlled rectifier (SCR) preregulator to limit the dissipation of the series regulator transistors. The high-current quadrupole power supply is capable of delivering up to 15-A dc while the normal quadrupole power supply is capable of only 7-A dc. The two units take up the same amount of panel space, and the high-current supply may be conveniently used instead of the normal power supply when quadrupole currents in excess of 7 A are desired.

### *Controllers*

The controllers used to set the output current level of each beam guidance, power supply provide two functions: (a) they permit local or remote control of the output current of each supply and (b) they contain 0.1%, 1-V shunts of which the outputs are used for metering the power supplies' currents in the I & C alcove and in CCR.

The degaussing and all quadrupole controllers are basically identical and will be described first. The steering dipole controller is different in several aspects and will be described last.

DEGAUSSING, QUADRUPOLE, AND POSITRON QUADRUPOLE CONTROLLERS. The controller (see Fig. 15-12) consists of a motor-driven potentiometer to set the output current of the associated power supply, local controls and a remote input to operate the motor, and a precision shunt is used for remote metering. The slight differences among the different controllers are given in Table 15-3.

The local controls are available on the controller's front panel. Normally the "local-remote" switch is in the remote position, and control may be

**Table 15-3 Comparison of controllers**

<i>Type of controller</i>	<i>Remote controls</i>	<i>Remote metering</i>	<i>Shunt output</i>
Degaussing	None	I & C alcove only	1 V at 20 A
Quadrupole	Raise-lower, power supply on-off from alcove and CCR	I & C alcove and CCR	1 V at 7.5 A
Positron quadrupole	Raise-lower from alcove	Sector 11 I & C alcove only	1 V at 15 A
Steering dipole	Raise-lower from alcove and CCR	I & C alcove and CCR	1 V at 20 A
High-current quadrupole	Raise-lower from alcove and CCR	I & C alcove and CCR	1 V at 15 A

transferred to the local position by keeping the switch depressed. By then pushing either the increase or decrease push buttons, proper polarity is fed to the dc motor to cause it to increase or decrease the resistance of the 10-turn potentiometer, causing the output current of the associated power supply to change. The power supply's output current is directly proportional to the potentiometer's resistance. When pressure is removed from the "local-remote" switch, control reverts automatically to the remote location which, by transmitting the proper voltage polarity, sets the output current of the associated power supply.

The analog voltage from the shunt is used in the local alcove and in CCR to measure the output current of the power supplies.

**STEERING DIPOLE, POWER SUPPLY CONTROLLER.** The steering dipole, power supply controller is different from the ones already described because it uses a stepping motor instead of a dc motor and it also uses a reversing relay to change the direction of current through the steering dipole coils.

A stepping motor is used to permit the output current of the power supply to be varied at a slow, medium, or fast rate. A pulse generator in CCR may be set to generate pulses at either 1, 10, or 100 pulses/sec. The pulses are transmitted through a pair of telephone wires to the controller. Electronic circuits inside the controller drive the stepping motor, causing the potentiometer to turn. Reversal of current direction through the magnet is accomplished by a relay when the load current is below 10-mA dc. Minimum current sensing is accomplished by ganging another 10-turn potentiometer on the same shaft as the control potentiometer and sensing when the control potentiometer is at zero, and, therefore, power supply output current is at minimum.

## 15-5 Beam analysis

### *Profile monitors (DDR)*

Beam profile monitors for use along the accelerator must meet requirements that differ appreciably from those for the BSY and research areas.<sup>8</sup> Some kinds of monitors are ruled out because of possible harmful effects upon the performance of the disk-loaded waveguide. Zinc sulfide screens, for example, might outgas, and might release harmful substances which could form deposits on the surfaces of the RF structure. The foils of a gas Cerenkov cell might rupture and leave fragments inside the critically tuned cavities. On the other hand, since the electron beam in the accelerator is confined to a small cross section, relatively high specific beam intensities can be expected, so that the monitors for the accelerator need not be so sensitive as those for the research areas.

Two types of profile monitors have been constructed for this application. One type, useful at relatively low beam power levels, makes use of a thin-quartz Cerenkov radiator which is viewed by a TV camera. The other type



was designed for use at very high beam power levels. In the high power or scanning monitor,<sup>9</sup> a small bead, typically a  $1 \times 1$ -mm molybdenum cylinder hung on a fine wire, is scanned over the beam profile. The bead scatters a small part of the beam, which hits the inner wall of the accelerator, making a shower downstream. The shower is measured by means of an ion chamber. The high-power monitor is poorly suited for the beam breakup (BBU) studies which have so far preoccupied experimenters who study the accelerator and its beam, since BBU does not repeat accurately from pulse to pulse. Apart from the BBU phenomenon, the beam profile has seemed to be well behaved and well understood. As a result, the scanning monitor has not, as of July 1967, been used as a tool for accelerator studies.

The Cerenkov TV monitors, illustrated in Fig. 15-13, have been installed at beam-analyzing station (BAS) 1 and in drift sections 1, 10, and 19. When one of these monitors is in operation, the electron beam passes through a 0.75-mm-thick fused quartz plate, producing light by the Cerenkov effect. The quartz radiator is mounted at a  $45^\circ$  angle to the electron beam so that the useful light will emerge at right angles to the quartz surface. Part of this light is reflected upward by a mirror and passes out of the accelerator vacuum region through a glass window. The light is observed by means of a closed-circuit TV system. Indicator units can be connected locally and are installed permanently at the injector control room and at CCR. To give reference marks, tungsten has been evaporated on the downstream surface of each quartz radiator to form a grid of  $0.25 \times 0.25$ -in. squares, as seen when viewed along the beam axis.

**Figure 15-13 Cerenkov-TV profile monitor for use along the accelerator.**

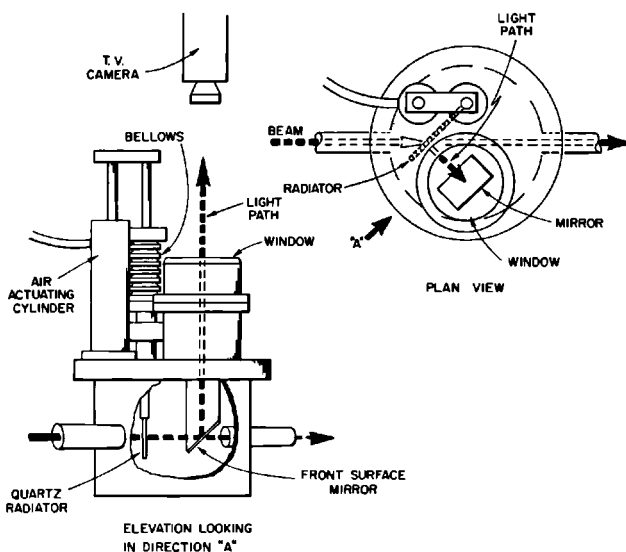

Unlike ordinary light, Cerenkov light is not radiated isotropically, but in a well-defined conical sheet. A description of this effect and other features of Cerenkov monitors is given by de Raad.<sup>8</sup> Due to the cone effect, it is necessary to take precautions to avoid mistakes when a TV camera is used to view a Cerenkov target. In early tests at BAS 1, for example, a very odd "profile" was once observed<sup>10</sup> which resulted from TV camera misalignment. After some confusion, it was found that the Cerenkov cone had been missing the camera entirely and that the TV camera automatic gain control had been operating in such a way that some very weak scattered light was visible, resulting in the misleading picture. In this case, a 25-mm wide-angle lens was installed so that the remotely operated camera pan and tilt mechanism could give adequate lateral motion and the camera could be properly aligned with the Cerenkov cone.

For regular installation along the accelerator housing, it was desired to use a lens of 75-mm focal length, so that the camera could be mounted well away from the beam line and yet give a fairly large image at the viewing screen. To eliminate the need for complicated camera positioning gear, the downstream surfaces of the Cerenkov targets have been roughened by sandblasting, to diffuse the Cerenkov light. When new  $f/1.8$  lenses and 7735B vidicons have been available, the systems, as of July 1967, have always been sufficiently sensitive to meet experimental demands.

Since the lenses become brown and the vidicons deteriorate seriously in a few months in the accelerator housing, it has become the practice to install cameras only when required, and to remove them when they are not in use. Nonbrowning vidicons are not used, since it appears that browning is not the life-determining factor. For initial installation, ordinary lenses were used. It is planned (July 1967) to procure and install some nonbrowning lenses, so that the browning rates of the two types can be compared. The quartz Cerenkov radiator itself remains in the accelerator vacuum; it is inserted into and withdrawn from the beam path by means of an air cylinder. The motion is accommodated by a stainless steel bellows which forms part of the accelerator vacuum wall. Some of the quartz radiators have been removed and have been found to have suffered some radiation damage. There is typically an oval brown spot, about  $2 \times 3$  cm, with an annealed clear spot near the center. In some cases, the quartz has been melted enough to smooth out part of the rough sandblasted surface. As of July 1967, the evaporated tungsten grids seem to have suffered no ill effects.

#### *Beam analysis stations (HAH, MJL)*

Two BAS have been built and installed on the accelerator. The first station, BAS 1, analyzes the beam after it has left the injector and has been accelerated through the first 40 ft of the machine. It is designed for energies up to 200 MeV. The second, BAS 2, was initially installed at the end of Sector 2, and served as beam dump and beam analyzer during the early tests while the

**Table 15-4 Summary of parameters for the beam analyzer stations**

<i>Parameter</i>	<i>BAS 1 (injector)</i>	<i>BAS 2 (Sector 2 test)</i>	<i>BAS 2 (Sector 20)</i>
Maximum energy	200 MeV	1.45 GeV	3.0 GeV
Maximum field required	8 kG	15 kG	15 kG
Maximum current required	120 A	300 A	300 A
Energy calibration	25 MeV/kG	96.7 MeV/kG	200 MeV/kG
Energy acceptance	25%	25%	25%
Bending radius	32.8 in.	126.9 in.	262.5 in.
Bending angle	30°	7.7°	3.75°
Pole-face rotation			
Entrance face	-1.5°	-12.4°	-14.4°
Exit face	-1.5°	-12.4°	-14.4°
Focal point location			
coordinates <sup>a</sup> $z' =$	60.5 in.	230.9 in.	465.8 in.
$y' =$	30.3 in.	30.2 in.	30.0 in.

<sup>a</sup> Position is measured relative to the point of intersection of the magnet entrance pole face and the beam axis.

remainder of the machine was being built. In this location, it could accept beam energies up to 1.45 GeV. At the beginning of 1966, BAS 2 was modified to enable it to analyze beam energies of 3 GeV, and it was moved to its permanent home at the beginning of Sector 20.

Both stations were invaluable tools for testing operation of the accelerator prior to its completion. Their utilization has tended to decline as operational experience and skill increase, permitting beams to be set up and passed directly to the switchyard for analysis. However, BAS 1 is used regularly for injector tune-up, and BAS 2 enables low-energy accelerator physics experiments to proceed while modifications are being made in the switchyard and end stations.

A summary of magnetic and optical design parameters for BAS 1 and the two forms of BAS 2 is given in Table 15-4. The basic optical arrangement of BAS 1 is shown in Fig. 15-14, which may also be used to identify parameters listed in Table 15-4 for BAS 2.

**OPTICAL DESIGN: DETERMINATION OF FOCAL POINTS** For electron energy  $E \gg m_0 c^2$ , the field intensity  $B_1$ , bending radius  $\rho$ , and energy  $E$  are related by<sup>11</sup>

$$\rho = \frac{E}{0.3B} \text{ (cm, MeV, kG)} \quad (15-22)$$

Similarly, the field intensity integral along the particle path is related to the bending angle  $\alpha$  and the energy by

$$\int B \cdot dl = \frac{\alpha E}{0.3} \text{ (kG, cm, rad, MeV)} \quad (15-23)$$

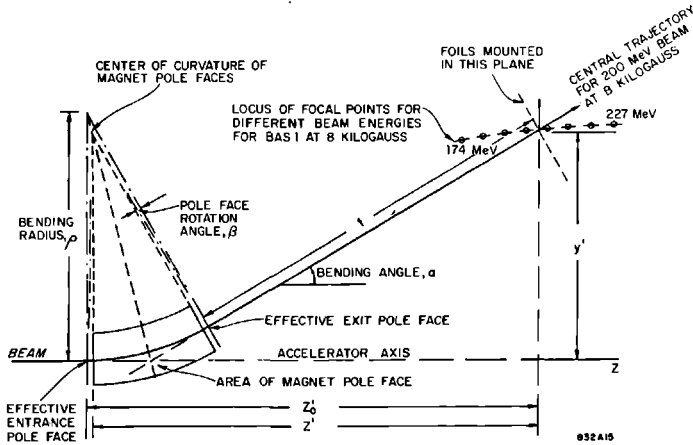

Figure 15-14 Basic optics: BAS 1.

The effective length  $l_{\text{eff}}$  of a trajectory through a magnet is defined to be the arc length of a trajectory through an ideal magnet (with uniform field  $B_{\text{max}}$  equal to the maximum field in the real magnet) which has the same bending angle. From Eqs. (15-22) and (15-23),

$$l_{\text{eff}} = \frac{1}{B_{\text{max}}} \int B \cdot dl = \frac{\alpha E}{0.3 B_{\text{max}}} \quad (15-24)$$

Referring to Fig. 15-14, it may be shown<sup>1,2</sup> that, for equal pole-face rotation angles,  $\beta$ , first-order theory gives

$$\begin{bmatrix} x \\ \theta \end{bmatrix} = \begin{bmatrix} \frac{\cos(\alpha - \beta)}{\cos \beta} & \rho \sin \alpha \\ \frac{-(1 + \tan^2 \beta) \sin(\alpha - 2\beta)}{\rho} & \frac{\cos(\alpha - \beta)}{\cos \beta} \end{bmatrix} \begin{bmatrix} x_0 \\ \theta_0 \end{bmatrix} \quad (15-25)$$

where  $x_0, \theta_0$  and  $x, \theta$  are the position and angle coordinates of beam trajectories at the entrance and exit pole faces, respectively, relative to the central trajectory at the same energy. The relative coordinates a distance  $t$  from the exit pole face will then be

$$\left. \begin{aligned} x' &= x + t\theta \\ \theta' &= \theta \end{aligned} \right\} \quad (15-26)$$

Now the focal point will be such that  $x' = 0$  for a parallel incident beam ( $\theta_0 = 0$ ). Inserting Eq. (15-26) into Eq. (15-25) with these conditions gives

$$\frac{\cos(\alpha - \beta)}{\cos \beta} - \frac{t(1 + \tan^2 \beta) \sin(\alpha - 2\beta)}{\rho} = 0$$

and, hence,

$$t = \frac{\rho \cos(\alpha - \beta) \cos \beta}{\sin(\alpha - 2\beta)} \quad (15-27)$$

From the geometry of Fig. 15-14, it is seen that

$$y' = t \sin \alpha + \rho(1 - \cos \alpha) \quad (15-28)$$

and

$$z'_0 = y' \cot \alpha + \rho \tan \frac{\alpha}{2} \quad (15-29)$$

Equations (15-27), (15-28), and (15-29) are used to calculate the position of the focal point. (Note that  $z' = z'_0 - d$ , where  $d$  is the separation of real and effective pole faces.)

A more general form of Eq. (15-25), to cover unequal entrance and exit pole-face rotations, was used to calculate the focal points for other energies. The locus of these points for BAS 1 is shown in Fig. 15-14.

The method outlined above was used to calculate the parameters in Table 15-4. For BAS 1, however, it was practicable to confirm the calculated values by the floating-wire method.<sup>13</sup> The trajectory of a beam of energy  $E$  through a magnet may be simulated by a fine wire under tension  $W$  carrying a current  $I_w$ . The relation is

$$E = 2.94 \frac{W}{I_w} \text{ (MeV, g, A)} \quad (15-30)$$

The annealed wire was clamped at a point along the central trajectory ( $\alpha = 30^\circ$ ) corresponding approximately to the calculated value of  $t$ . The wire passed through the magnet and over pulley supported on air bearings. Weights on the free end supplied a suitable tension (approximately 50 g), and  $I_w$  was adjusted to satisfy Eq. (15-30) for  $E = 200$  MeV;  $B$  was adjusted so that the wire between the pulley and the entrance pole face coincided with the accelerator axis. Then, by trial and error, the value of  $t$  was found for which, when the pulley was moved up and down, the wire between it and the magnet remained strictly parallel to the accelerator axis. This value of  $t$  defined the focal point. Theoretical and experimental focal points coincided within 1%. The floating-wire test could not be used for BAS 2 because of the large values of  $t$  involved. It was used, however, to check the calculated value of the effective length of the magnet.

**ELECTROMAGNET CHARACTERISTICS.** The same design of magnet was used for both BAS 1 and BAS 2. Each magnet has a U-shaped yoke, with arcuate pole pieces (mean radius 30 in., angle of arc  $30^\circ$ ) fitted inside the yoke and carrying the energizing coils. The field variation is less than 0.1% over a zone  $\frac{3}{4}$  in. wide on each side of the central arc. The field is 15 kG for a current of 300 A, with about 20% saturation at that level.

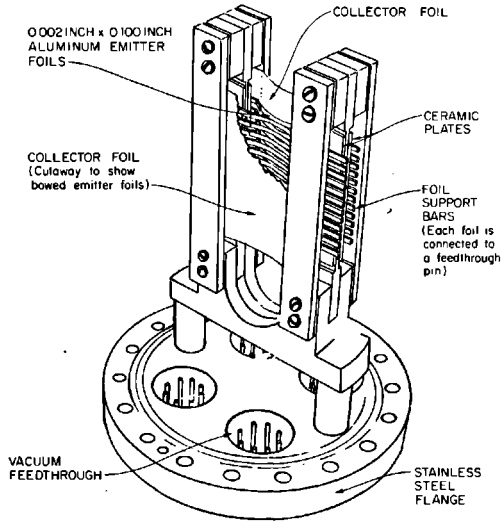

**Figure 15-15 Secondary-emission foil assemblies: BAS 1 and 2.**

**ENERGY ANALYZER FOILS.** The beam, deflected and spread out into an energy spectrum by the magnet, is detected by a series of secondary-emission monitors. The monitor assembly is shown in Fig. 15-15. Twenty-four aluminum foils, each 0.002-in. thick and 0.100 in. wide, are mounted horizontally in the plane shown in Fig. 15-14, normal to the central trajectory. The top foil, for which the analyzer is calibrated, crosses the central trajectory. The remaining twenty-three foils are mounted immediately below alternately, on opposite sides of alumina support strips, so that they are insulated from each other and yet beam interception is continuous. From Eq. (15-24),

$$\frac{\Delta E}{E} = -\frac{\rho}{l_{\text{eff}}} \Delta\alpha = -\frac{\rho}{l_{\text{eff}}} \cdot \frac{w}{t} \quad (15-31)$$

where  $w$  is the foil width. All foils are 0.100 in. wide, giving  $\Delta E/E \approx 0.33\%$ . The foils are bowed to avoid "oil-canning" when they are heated by the beam. Large collector foils biased 120 V positive with respect to the emitter foils are mounted on each side.

Each emitter foil is connected to the center conductor of a low-capacity coaxial cable which runs up to the foil scanner in the klystron gallery. The outer conductors of all twenty-four cables are connected to the two collector foils. All cables are terminated in 100-megohm loads, giving an  $RC$  time constant of about 0.1 sec. in each case.

Assuming that 10% of the analyzed beam current strikes one foil<sup>14</sup> and that the secondary emission efficiency (both sides) is 4%, the foil current for a 1-mA beam is 4  $\mu\text{A}$ . Thus, for a 1.6- $\mu\text{sec}$  beam pulse length and 1000-pF

distributed cable capacity  $C$ , the pulse voltage is  $\Delta V = 6.4$  mV. If the time  $T$  between beam pulses is approximately 17 msec (60 pulses/sec), then the steady-state voltage built up across the terminating resistor is

$$V = \frac{\Delta V}{1 - e^{-T/RC}} = 41 \text{ mV}$$

If the voltage is sampled every twenty pulses, it will rise to about 95% of its steady-state value.

The output of the top foil is amplified and applied to the  $y$  channel of an  $x - y$  recorder. A voltage proportional to the electromagnet current is applied to the  $x$  channel. Thus, as the magnet current is raised, a detailed plot of relative beam current versus energy is obtained.

Voltages from the remaining twenty-three foils are scanned sequentially by means of a series of reed delays driven by a ring counter. The circuit is designed to allow adequate time for one relay to open before the next one closes, preventing charge leakage between foils. The scanned outputs are displayed on an oscilloscope, appearing as a histogram of beam current in each 0.33% energy interval.

The foils for BAS 2 are longer than for BAS 1; otherwise, the two assemblies are identical.

**GENERAL DESCRIPTION OF BAS 1.** The main features of BAS 1 can be seen in Fig. 15-16. The station is mounted on a 10-ft drift-section girder. The beam runs through a stainless steel "Y" vacuum envelope inside the magnet, allowing the beam to go straight ahead when the magnet is degaussed or to be

**Figure 15-16** Layout of BAS 1.

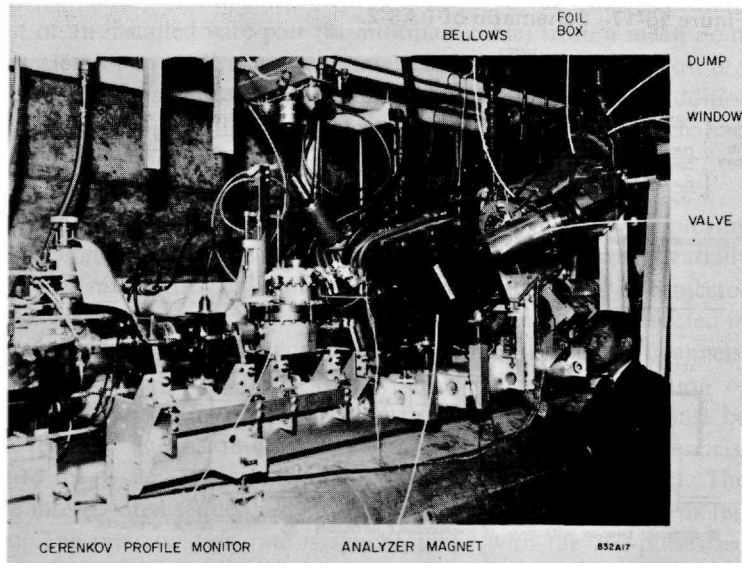

bent up into the large cylindrical chamber known as the foil box. A large manual valve permits the foil box to be isolated from the accelerator vacuum system. The foil assembly is mounted on the underside of the foil box just below the copper vacuum window, through which the beam passes to be absorbed in the beam dump. A large bellows permits adjustment of the foil box position. The copper window is water-cooled and reduced in thickness along the beam interception area to minimize heating. The lead-shielded dump is a complex design of stacked copper plates (to prevent the cracking which could occur at the shower maximum in a solid block), peripherally water-cooled. It will dissipate 40 kW. The system is protected by thermal switches on the magnet cooling water, flow switches on all water supplies, thermocouples (operating meter-relays) on the dump, window, and valve, limit switches on the valve and the dump (which can be moved for maintenance), and secondary-emission foils<sup>15</sup> (operating in air) to protect the "Y" from beam interception. Tripping any interlock shuts off the beam. The station can be controlled from either the rack containing the magnet power supply or from the injector console.

**GENERAL DESCRIPTION OF BAS 2.** Figure 15-17 shows the layout of BAS 2 in schematic form. The station, which is mounted on the first girder in Sector 20, has the same main components as described for BAS 1, with the exception of the manual valve to isolate the foil box. The "box" is an 8-in. diameter stainless steel pipe about 38 ft long. The magnet, the large "Y" section, and a beam stopper (for emergency protection of people working in the switchyard while a beam is being run into BAS 2) occupy the first 10 ft of the girder. These are followed by a 10-ft drift tube. Two accelerator sections are mounted in the last 20 ft. The beam stopper, which is a copper bar inside the vacuum

Figure 15-17 Schematic of BAS 2.

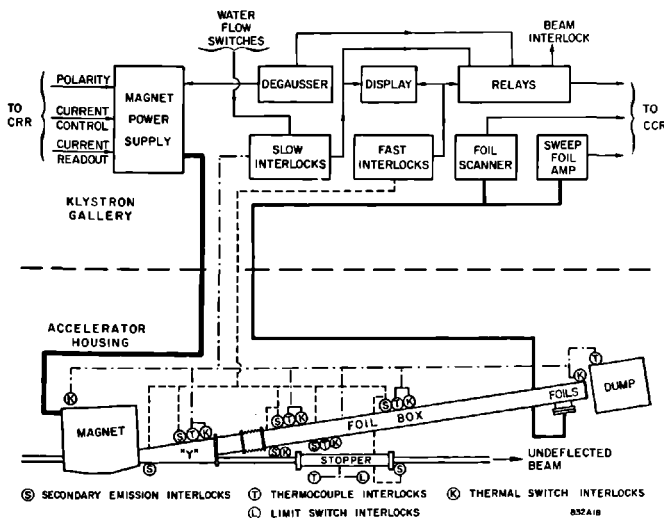



system, can be remotely moved into and out of the beam line. The dump for BAS 2 is attached to the ceiling of the accelerator housing. It consists of six copper blocks, each 2 in. thick. The first four blocks are water-cooled. The dump is rated at 35 kW, and is lead-shielded for personnel protection from residual radioactivity.

The station is protected by an extensive system of interlocks of the types described for BAS 1 and located as shown in Fig. 15-17. The secondary-emission foils mounted in air around the vacuum envelope trigger a fast fault system which will trip on a single pulse and reset after 1 sec. All other protection devices operate a "slow fault" circuit. A fault summary panel in the local rack indicates the location of the trouble.

The BAS 2 is normally operated from CCR. All incoming control signals are amplified by SCR circuits which drive dc relays. A PWM signal is applied to a dc motor regulating the current level of the bending magnet power supply, giving a very wide range of speed control for exploring and plotting spectra. A current and polarity programmer automatically degausses the analyzer magnet when a straight-ahead beam is required.

## 15-6 Data-handling systems (KFC)

### *Status monitoring system*

There are approximately 3000 status signals generated in the sectors, the injector, and the BSY. The signals represent, typically, the condition of valves (open-closed), vacuum (OK-not OK), modulators (OK-not OK), etc. It is the function of the status monitoring system to (1) collect these data, (2) transmit the signals to the CCR, and (3) provide drive voltages for lamps on the display consoles. Direct wire-pair transmission was considered for this application, but the cost of an installed wire-pair (in multipair cable) from a mean point along the accelerator to CCR is approximately \$150. The equivalent cost of a solid-state multiplex transmission system is \$40-\$50 per signal. In addition to the cost advantage, multiplex equipment can be expanded in channel capacity quickly and conveniently by plug-in cards.

**SYSTEM DESCRIPTION.** The selected system employs time-division multiplexing techniques, whereby each input at a remote location is sampled sequentially every 600 msec. Transmitting equipment is located in each sector, the injector and the DAB in the beam switchyard. All receiving equipment is located in the CCR. As initially installed, the equipment is strapped to scan 108 channels. Expansion to 156 inputs can be easily accomplished without addition of equipment at the transmitting location; however, output modules must be added at the receiver. The maximum capacity of the equipment is 252 channels. Each input to the system is made available as a floating relay contact. The contacts are interrogated sequentially by a digital multiplexer at a rate of 180 contacts/sec. The interrogation rate is synchronized with the 360-pulses/sec

accelerator clock. The multiplexer output is processed in an encoder which inserts the frame synchronizing signal (three binary "ones" followed by a binary "zero") and generates the binary data wave train. A closed status contact is represented by a logic "1" followed by "0," and an open contact is a "0" followed by "1." This type of code has two important features: (1) it provides redundancy for simple error checking at the receiving location, and (2) it carries its own bit-synchronizing signal.

The binary wave train modulates a frequency shift transmitter which has a nominal frequency of 18.8 kHz and a frequency shift of  $\pm 250$  Hz. The carrier signal is transmitted on a wire-pair to CCR where the binary signal is demodulated in a frequency shift receiver. The receiver output is checked for transmission errors in a decoder and converted to parallel format in a serial-to-parallel converter. The parallel outputs feed to output modules. The module consists of a memory flip-flop to prevent relay dropout between successive data scans and a driver to operate an external relay.

**TRANSMITTING EQUIPMENT.** The transmitting equipment consists of an encoder and a frequency shift transmitter (see Fig. 15-18). The function inputs at the remote station are provided by up to 156 normally open or normally closed contacts. In the open condition, a scanning current of 2 mA is provided in turn to each of these contacts. When open, the voltage across the contacts is 18 V.

The encoder scans all input functions and generates a binary coded pulse train as shown in Fig. 15-19. The scanning operation is accomplished by a basic counter and matrix which sequentially scans the sixteen input functions in each group. Each group is enabled in sequence by a group counter and

**Figure 15-18 Remote station (transmitter), 252-channel system.**

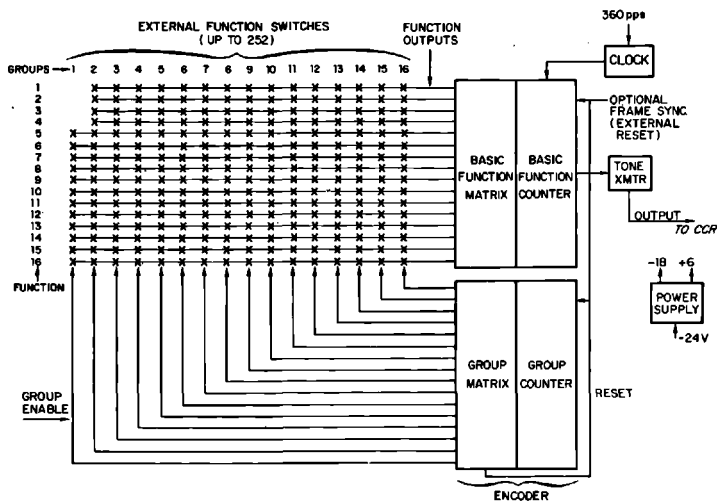

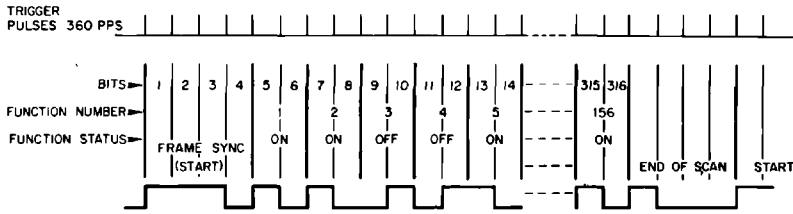

Figure 15-19 Encoder output waveform.

matrix. Ten group outputs have been provided, but as many as sixteen groups can be installed. The counters are continually advanced by pulses from an internal clock which is synchronized with the accelerator 360-pulses/sec trigger. If the 360-pulses/sec trigger input fails, the internal clock will continue to run at approximately 350 pulses/sec.

The binary pulse train from the encoder is used to shift the frequency of a transmitter between 18.550 and 19.050 kHz. Carriers in other frequency bands can be transmitted on the same wire-pair if expansion of the system is required. The transmitter output voltage is 1.3 V rms maximum, into a balanced 135-ohm wire-pair. Harmonic distortion is 5% maximum and amplitude modulation is less than 20%.

The input power is from the local -24-V battery. The supply output is +6 V regulated, and -18 V unregulated.

RECEIVING EQUIPMENT. The receiving equipment consists of a frequency shift receiver and a decoder for each transmitting location and an additional decoder for each switched sector panel (see Fig. 15-20).

Figure 15-20 Receiving equipment—252-channel system.

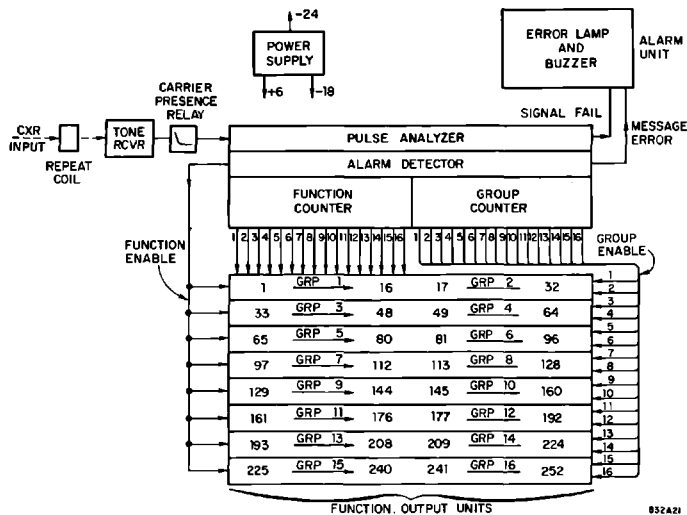

The receiver delivers a voltage output that is a reproduction of the pulse train applied to the remote transmitter. If the carrier level drops below a preset level, audible and lamp alarms are generated.

The decoder consists of the following subassemblies:

- PULSE ANALYZER—decodes message to provide function status display and extracts frame synchronizing and bit synchronizing signals
- ALARM DETECTOR—performs error checks on the message. If message contains extra pulses, extra spaces, missing pulses, missing spaces, or wrong parity count, an alarm signal is generated
- COUNTER UNITS—Contain basic function counter and group counter
- AUDIBLE ALARM UNIT—Sounds internal alarm buzzer when error is detected or carrier fails
- OUTPUT MODULE—Provides memory and drive for external relay
- POWER SUPPLY—Operates from local -24-V battery; generates 6 V regulated, and -18 V unregulated.

The arrangement of equipment in CCR is shown in Fig. 15-21. Continuous decoding and display are provided for the injector and the BSY. In addition, thirty-two channels are continuously displayed from each sector. All status channels (156 maximum) from any three sectors can be monitored on display panels, one on the operator's console and two on the maintenance console.

Figure 15-21 Block diagram of status monitoring system.

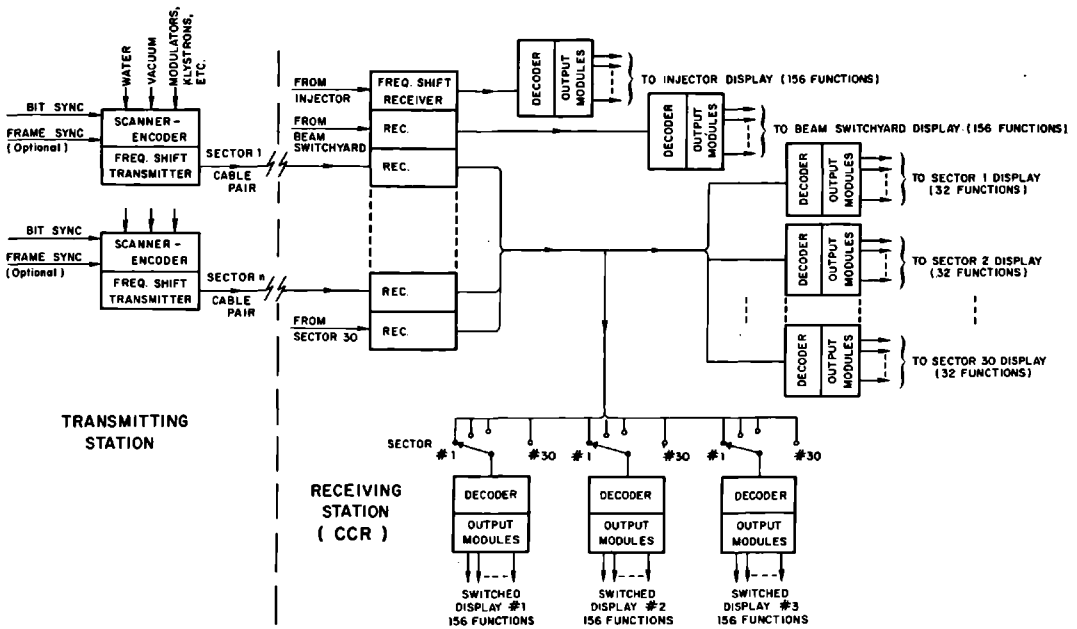

### Remote control system

For efficient operation of the accelerator, it is essential that the CCR operator be provided with the means for remotely controlling equipment in the sectors, the injectors, and the BSY.

The system adopted for the accelerator uses binary coded relays. A code applied in parallel to six wire-pairs looped from sector to sector is decoded by a relay tree at the selected sector. Sixty-four channels are thus available. A control voltage applied to a seventh pair determines whether the remote device is turned on or off. Response time for the system is approximately 200 msec.

**SYSTEM DESCRIPTION.** The CCR console switches are grouped on the injector, BSY, and sector panels. (See Fig. 15-22.) There are three identical switched sector panels, allowing access to any three different sectors simultaneously.

Operation of the injector system will be described first. The description applies equally to the BSY system. When a control switch is pressed, one of sixty-four encoding relays in CCR operates. This relay, corresponding to the decimal number of the channel, operates to apply a code to the six wire-pairs and to "lock out" all but the selected channel. A binary "one" is transmitted as a "tip-positive" 48-V signal and a binary "zero" is transmitted as a "tip-negative" 48-V signal.

One of the two control relays also operates, depending on the command, "on" or "off." The control relay applies 48 V to the seventh pair.

Figure 15-22 Block diagram of remote control system.

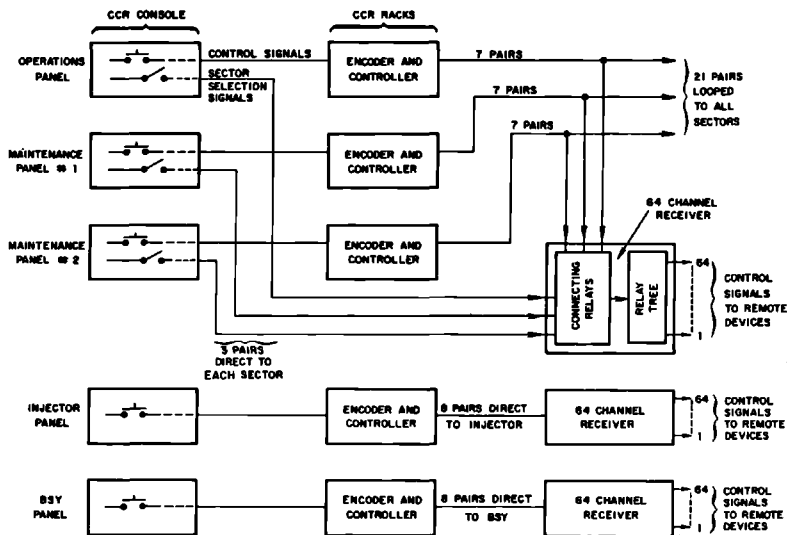

At the injector, a relay tree decoder converts the six binary inputs to the appropriate decimal number and completes a circuit from the local 24-V battery to the selected device via contacts of a control relay. This relay, operated by the seventh pair, serves to reverse the local battery depending on the "on" or "off" command from CCR. The load current available to remote devices is fused at 2A. The applied voltage is present only while the CCR switch is depressed. For devices requiring a holding current, external latching relays are added.

Operation of the sector system is similar except for the requirement that only one switched sector panel at a time can operate in a particular sector. The operator's console has priority over maintenance No. 1, and maintenance No. 1 has priority over No. 2. Only the highest priority panel can control or monitor a selected sector. Seven looped pairs (6 binary, 1 control) are associated with each panel. In addition, each panel has thirty long-haul pairs to the sector receivers, one for each sector-select button. When a sector is selected, the long-haul pair applies voltage to one of three relays in the receiver. The relay acts to connect the relay tree to the appropriate set of looped cables. Control of remote devices can then be exercised by operating the control switch. If the same sector is selected by a panel of higher priority, the first connecting relay drops out and the second connects the receiver to the second set of looped cables.

Provision has been made for pulsing of remote stepping motors. A strap is added to the particular channel so that a control pulser is started whenever the channel is selected. The pulser breaks the control pair at any one of several preset rates (1, 2, 5, 10, 50 pulses/sec).

**SPECIAL CONTROL CHANNELS.** In certain cases, the "one channel at a time" feature of the relay tree is undesirable because simultaneous access is required for two or more functions at a particular location. Vertical and horizontal steering is an example of this. Separate hard wire pairs are used for these applications. The transmitting voltage is 48 V, pulsed at 1, 10, or 100 pulses/sec.

### *Analog system*

The analog system provides the CCR operator with D'Arsonval meter displays of dc signals from remote information sources. Typical sources are steering coil currents, quadrupole current, and VVS reference voltage. The method adopted for the accelerator is a simple dc transmission system using one wire-pair per signal. The transmission level is 0–5 V dc, 0–1 V dc, or  $\pm 1$  V dc, depending on the source characteristics.

A number of possible approaches were examined in detail before selecting this straightforward system. These included remote multiplexing of the signals with time-division transmission, using pulse amplitude, pulse duration, or pulse code modulation. Other proposed methods would have used frequency-division techniques. The overriding factors in the choice of hard wire were

lower cost and adequate accuracy. For most signals,  $\pm 3\%$  of full scale appears to be satisfactory. In cases where short-term accuracy of better than  $3\%$  is required, digital voltmeter or slideback voltmeter circuits are used.

**SYSTEM DESCRIPTION.** There are thirteen signals from a typical sector. Six of these are displayed continuously in CCR and the remainder are displayed on three identical panels on the CCR console. Each of these panels can be switched to display the analog signals in any one sector.

Seven injector signals are displayed continuously on console meters and eighteen are displayed on one meter via a selector switch. Beam switchyard signals are also divided into continuous displays (10) and switched displays (20).

**EQUIPMENT DESCRIPTION.** All analog sources are basically voltage sources of low impedance (1000 ohms maximum). Line current is approximately  $105\ \mu\text{A}$  at full scale, determined by a multiplier at the CCR meter. For the switched analog displays from the sectors, the signal can be displayed on any one of three switched panels. The three meters are connected in series, and when a meter is switched out of circuit, the total circuit resistance is restored by switching in a fixed resistor. Figure 15-23 is a simplified circuit of the three-meter arrangement.

In most cases, the source voltage is provided by the equipment itself. For example, the variable voltage transformer is supplied by a dc rectifier in the reference voltage subsystem. When an internal voltage source is not available, voltage is supplied by a Zener regulator in the analog metering panel located in each sector alcove. The metering panel also allows sector monitoring of signals without disturbing the CCR reading and provides a series potentiometer for current adjustment of each signal circuit.

**SOURCES OF ERROR.** The long-haul cable pair is 22 gauge which, for a 2-mile run, has a nominal loop resistance of 380 ohms. Over a temperature range of

**Figure 15-23** Simplified functional schematic diagram of a typical analog signal circuit.

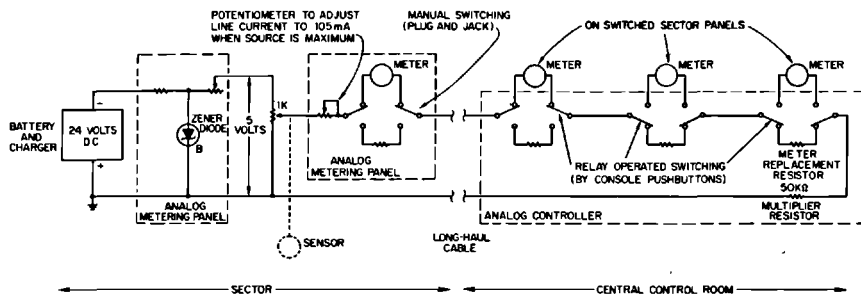

$\pm 20^{\circ}\text{C}$ , the maximum error introduced by temperature is  $\pm 0.08\%$  of full scale.

Several analog voltage sources utilize shaft position potentiometers. The change of source impedance with change in shaft position introduces 0.3% of full scale error.

The small panel meters used have an accuracy of  $\pm 2\%$  of full scale ( $100\ \mu\text{A}$ ). The system accuracy has been improved by shunting all meters to read full scale when the circuit current is  $105\ \mu\text{A}$ . Thus differences on individual meters can be eliminated at full-scale reading. Nonlinearity at readings less than full scale are still present, however, and are of the order of  $\pm 1\%$ . The 5-V source in the analog metering panel has a stability of  $\pm 0.13\%$  over  $\pm 25^{\circ}\text{C}$  and will hold the voltage to  $\pm 0.2\%$  with normal variations of input voltage from the 24-V battery system.

The CCR equipment for selecting a particular sector for display is mounted in the rack area of CCR. It consists of six relay chassis called "analog controllers." The function is to select any group of 45 signals (up to 15 signals from each of three sectors) from 450 input signals (up to 15 signals from each of thirty sectors). A block diagram is shown in Fig. 15-24.

*Video cable system*

There are a number of video signals generated in the sectors, injector, and BSY which are made available to the CCR operator. The signals include toroid pulses, video pulses from the phasing system, and TV signals. The cost of

**Figure 15-24** Central Control Room equipment analog system.

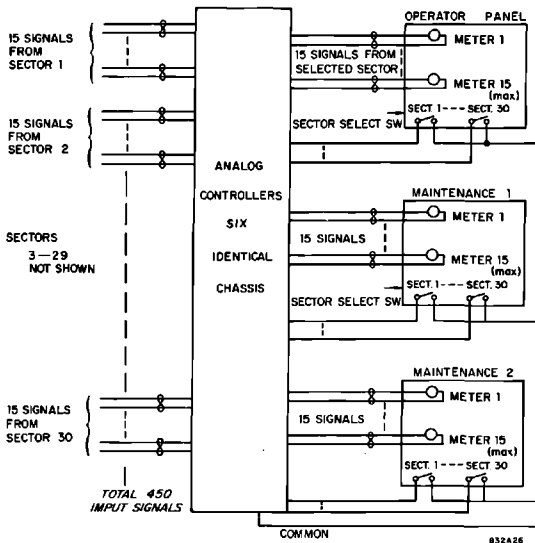



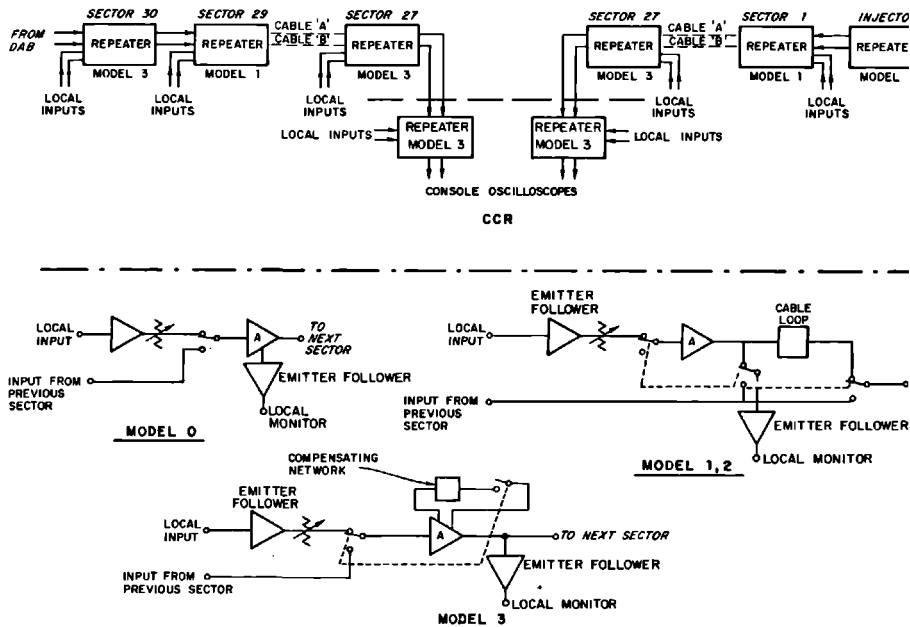

Figure 15-25 Video cable system.

high-quality coaxial cable with a rise time of the order of 100 nsec over 10,000 ft would have been prohibitive. The system adopted for the accelerator uses a lower-quality cable in conjunction with compensating techniques.

**SYSTEM DESCRIPTION.** There are four independent cable channels—two from the DAB via Sectors 30–27 to CCR and two from the injector via Sectors 1–27 to CCR. (See Fig. 15–25.)

Signals may be transmitted from the injector to CCR, CCR to the injector, or introduced at any intermediate sector and transmitted in either direction. The same flexibility exists for the CCR–DAB cable.

A system rise time of approximately 50 nsec has been achieved by the use of compensated repeaters every third sector (Sectors 3, 6, 9, etc.).

Four different repeater models have been installed. Model 0 in the injector consists of an amplifier with gain steps of 0.5, 1, 2, 5, and 10. Model 1 in Sectors 1, 4, etc., is used only to introduce local signals through an amplifier identical to model 0, except that the signal passes through a coaxial cable loop. The coaxial cable has loss characteristics equal to the loss of a signal transmitted 333 ft from the previous sector. For signals transmitted from the injector to CCR, the repeater is bypassed completely.

Similarly, a model 2 is installed in Sectors 2, 5, etc. For locally introduced signals, a coaxial cable loop simulates the loss of transmission over two sectors. For through transmission, the repeater is bypassed.

Model 3, in Sectors 3, 6, etc., contains a compensation network in the amplifier feedback network. The network is in the circuit for signals transmitted from a previous sector but is not used for local signals.

Provision has been made for remote control of local gain, the selection of one of a number of available local inputs, and for the reversal of input and output connections. System operation is returned to the normal mode, injector to CCR or DAB to CCR, by operation of a "clear" button on the CCR console. Rotary switches in each repeater step to a "home" position and transfer command to the next repeater down the line.

#### SYSTEM PERFORMANCE

Rise time: 50 nsec 0–90 %

Droop: less than 10 % in 10  $\mu$ sec

Signal amplitude:  $\pm 2.5$  V peak-to-peak maximum

Cable type: FHJ450  $\frac{1}{2}$ -in. foam heliax.

### 15-7 Central control (DDR)

#### *Introduction*

The accelerator control system is arranged so that, after the necessary components are made ready for use by operations performed along the klystron gallery, all controls necessary to normal operation can be operated from the CCR. In addition to controls and indicators required for normal operation, some equipment has been provided in CCR for use in detection, evaluation, and location of abnormalities, so that maintenance personnel can efficiently be dispatched for necessary repairs. Other equipment has been provided for the coordination of accelerator control with activities in the beam switchyard and in the experimental area.

When the SLAC control system is compared with those of smaller accelerators, it will be noted that the number and quality of signals exchanged between CCR and remote components have been stringently limited. No pulse shape information is ordinarily transmitted from accelerator components to CCR. Instead, a few pulse channels have been made available for occasional special use. Whenever possible, analog signals, such as voltmeter readings, have been replaced by status, or "go-no go" signals. Klystrons and modulators, for example, do not originate any analog signals in the CCR. The number of status signals transmitted to CCR has also been reduced by eliminating some signals and by transmitting logical combinations of certain others on single channels. In all, about 500 slow analog signals and 3000 status signals are available for display on meters and lamps in CCR. The response time of status and analog channels is nominally 1 sec. In addition, some 200 PAM signals are received in CCR from beam position, intensity, and spectrum monitors for display on oscilloscopes. Most of these signals are updated 360 times/sec. An important part of CCR instrument design has been aimed at

coping with multiple beams. Special oscilloscopes have been provided, in which base line position and trace intensity modulation can be used to distinguish data belonging to different beams.

Roughly 1200 remote control channels fan out from CCR to the injector, positron source, thirty sectors, beam switchyard, and other remote points. These channels transmit pulses of 5 msec and longer, originating in a 48-V dc source, over telephone wire-pairs. For wiring economy, most of these channels make use of relay trees, which operate remote equipment in accordance with binary coded control signals, each transmitted upon several wire-pairs. Response times of relay tree control operations are in the 0.1-0.5-sec range. The remote control channels for the beam-steering dipole controls are each assigned a separate wire-pair and give faster response.

### General description

The CCR for the accelerator is arranged as shown in Fig. 15-26. Much of the space is devoted to signal-handling equipment which is connected, mostly by means of telephone cables, to components along the accelerator. The controls and indicators that terminate the communications systems in CCR are located in the console area. The console area is divided into four regions, corresponding to four kinds of activities. These activities are operation, maintenance, programming, and studies. Each of the first two activities is provided with a separate console. Much of the programming is done at the so-called backup

Figure 15-26 Central control layout.

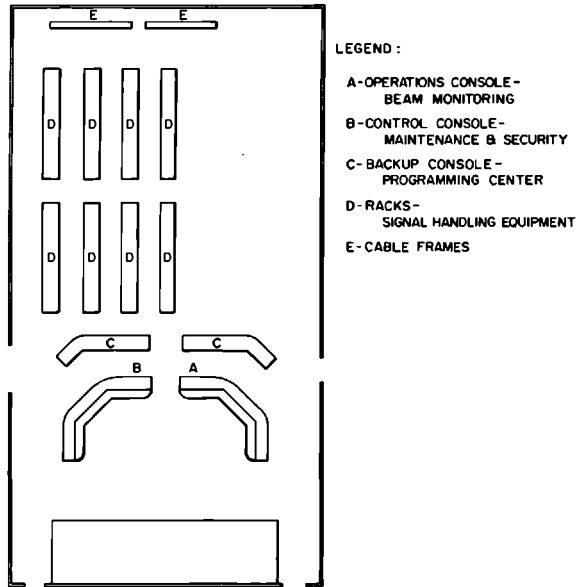

console. The studies area consists of extra space, centrally located in the consoles, to provide mounting space for special instruments, with convenient accessibility to a large number of the permanently installed instruments.

Because of the structure of the signal-handling equipment, it is generally most convenient and economical to arrange control panels on a geographic basis in CCR. Three identical panel assemblies called "switched sector panels," two in the maintenance console and one in the operations console, contain transmitting and receiving terminals for connection to the thirty sectors which comprise the greater part of the accelerator. Any of these panels can be connected to any sector. A priority arrangement prevents more than one panel at a time from being connected to any sector. Similar panel assemblies terminate monitoring and control channels connected to the injector, DAB, and other remote locations.

Some instruments are arranged on a subsystem basis. There are long rows of meters in the backup console which show vacuum gauge readings, radiation levels, and steering current values along the accelerator. In the maintenance console all the most urgent, sector alarm status indicators are arranged on two panels, side by side. Two more panels contain essential status information for all the klystrons along the gallery except certain special ones. In the beam operator's console, many of the controls and displays are arranged on a subsystem basis, notably the steering controls, some alarm signal lamps, and the multiplexed displays presented by the steering and spectrum oscilloscope.

### *Operation*

At least one man sits at the beam operator's console (Fig. 15-26) and is responsible for making adjustments so that the electron beam can meet the requirements of the experiments. Controls and indicators not necessary for adjusting and monitoring beam parameters have largely been excluded from the panel space within easy reach of the beam operator. In this way, it has been possible to place within arm's reach those instruments that he uses most frequently.

**INJECTOR ADJUSTMENTS.** In the injector panel, the beam operator has controls and indicators to adjust beam pulse heights, lengths, and delays, focusing coil and quadrupole currents in the injector, and the frequency of the master oscillator. The same panel contains status lamp indicators for the principal injector components. Another panel, called the phase closure panel, contains remote controls for several phase shifters belonging to the injector system. These are used to optimize electron bunch parameters and the beam energy spectrum. In addition to meters that verify the action of remote controls, there are pulse oscilloscopes which may be connected to selected pulse sources in the injector and elsewhere. These oscilloscopes have controls to displace base lines and to brighten or dim traces to help distinguish pulses belonging to different beams.

**BEAM GUIDANCE AND MONITORING.** One of the beam operator's major jobs is to steer the beam, using adjustable magnetic dipole deflection coils, so that it can travel 3 km through a 2.2-cm diameter hole without striking the wall anywhere. Two long rows containing thirty-nine lever switches each are provided for the control of the vertical and horizontal steering dipoles installed along the accelerator waveguide. Above the steering switches are four oscilloscopes which display multiplexed signals, originating from beam intensity and position monitors installed along the accelerator. Each indicator can be made to display up to six rows of dots, corresponding to beam intensity or position along the machine for up to six electron beams. Two of these units indicate vertical and horizontal steering errors. One displays beam intensity or linear  $Q$ , measured by toroidal ferrite core monitors. The other unit shows  $\log Q$ , a signal generated as a by-product in the normalizing circuits that convert 2856-MHz signals to vertical and horizontal steering error signals. To help reduce error and confusion in the beam steering operation, a special brightening circuit has been provided. When a steering switch is operated this circuit brightens a dot on the appropriate position monitoring oscilloscope which corresponds to the position monitor readout at the end of the next sector. Another oscilloscope displays a video pulse train, originating in the machine protection, long ion chamber (PLIC); its signal indicates beam power loss as a function of distance along the machine. The PLIC oscilloscope is frequently very useful in beam steering and focusing adjustments. The PLIC signal is also connected to a discriminator which shuts off the beam whenever the PLIC signal exceeds a preset level.

The electron beam is focused by quadrupoles installed at intervals along the accelerator, which are adjusted by means of controls in a switched sector panel, located to the beam operator's left. Quadrupole currents can also be adjusted through the two similar panels in the maintenance console.

**ENERGY SPECTRUM MONITORING AND ADJUSTMENT.** In the BSY the electron beam is magnetically deflected and its spectrum analyzed. The spectrum signals are multiplexed in the DAB, transmitted to CCR, and displayed on two oscilloscopes, one for each end station, in the beam operator's console. To produce a good energy spectrum, the beam operator must first switch to the "accelerate" state as many klystrons as are necessary to produce slightly more than the required beam energy, making sure that all klystrons are properly phased. Then, he must misphase two klystrons, adjusting by equal and opposite amounts until the beam energy is correct. In this way, he can make the length of the effective accelerating voltage vector of the whole machine equal to the required beam energy per electron. To produce a narrow spectrum, he must also make sure that the phase of the machine voltage vector and the mean phase of the electron bunch are identical. In addition, he must correct for beam loading by a timing adjustment, making some klystrons fire about 0.8  $\mu$ sec late. Producing a good spectrum is sometimes a "cut-and-try" process. Upon occasion, the operator must make small adjustments in each

parameter, and watch the effect of each upon the spectrum shape before he proceeds to make another trial adjustment.

For the purposes of energy control, high-power klystrons along the machine can be divided into four classes. Klystrons belonging to the injector, Sector 1, and the positron source are not ordinarily manipulated for energy control. Klystrons in Sector 28 have special pattern controls, so that they can each be assigned to any beam or combination of beams, or switched to "standby." Klystrons in Sector 27 have pattern controls like those in Sector 28, and in addition each has a phasing control that is manually adjustable by the beam operator. The remaining klystrons are all divided, for pulse pattern purposes, into sector groups of eight. All klystrons in each ordinary sector are constrained to pulse on the same pattern when they are in the "accelerate" state. Any of these klystrons can be switched to the "standby" state by the beam operator. In this state, a klystron continues to pulse, producing its normal RF power output at its normal rate, but with its trigger timed to be 20 to 30  $\mu$ sec too late to accelerate the beam. Unlike the practice with some linacs, at SLAC the klystron pulse heights are not ordinarily adjusted to control beam energy.

The spectrum oscilloscopes, the special controls, and indicators for Sectors 27 and 28, the phase closure panel, and certain other indicators related to the BSY and DAB are all located in one rack immediately to the right of the beam operator's switched sector panel, which forms the extreme left end of the operations panel cluster. The switched sector panel contains controls and indicators used for switching klystrons to "accelerate" or "standby," and for sector timing and phasing adjustments. At the time of writing (July 1967), it is planned to install circuits along the machine which would reduce the time and effort required to select and switch klystrons to "accelerate" or to "standby" by making these operations largely automatic. Controls and indicators for this system will be mounted to the operator's right. With this system, it is hoped to reduce the downtime occasioned by malfunctioning klystrons and modulators.

### *Maintenance and servicing*

The success of the beam operator depends upon satisfying many preliminary requirements. The maintenance supervisor is responsible for seeing that the hardware requirements are met and for dispatching maintenance men and materials along the klystron gallery as required. He is also responsible for monitoring and controlling the personnel and machine protection systems. In the maintenance console (Fig. 15-26), he has two switched sector panels, similar to the one provided for the beam operator. Each has detailed indicators which report such faults as open interlocks, faulty klystrons, closed valves, defective power supplies, and other obstacles to satisfactory beam operation, in any sector to which it is connected. Each has many remote control buttons. Some remote control functions are adjusting klystron pulse voltage and sub-booster phasing and timing, initiating the automatic phasing program,

switching klystrons to “accelerate” or “standby,” and operating safety interlock relays. In each case, a status lamp or a panel meter indicates the response to the control action. Panels similar to switched sector panels are provided in the maintenance console which terminate signal channels between CCR and the injector and BSY. Other panels provide indications of the status of special elements of the machine and personnel protection systems, and the remote controls belonging to these systems.

### *Programming*

Preliminary adjustments must be made upon occasion in order to establish a new set of electron beam parameters so that a new experiment may be brought into operation. These changes must be made in such a way as to cause the least possible interference with experiments in progress. Part of this problem can be solved by proper switching of pulse pattern circuits and indicator circuits. This activity is carried out largely in the programming area in the backup console, indicated in Fig. 15-26. The backup console also contains remote controls and indicators which are less frequently used than those which are mounted in the operations and maintenance consoles.

### *Acknowledgments*

The successful completion of the two beam analyzer stations in time for the early beam tests was largely due to the work of E. L. Roskowski, who did almost all the mechanical design work and supervised fabrication, installation, and testing. The control and readout electronics systems were designed and tested by A. R. Wilmunder. Thanks are also due H. Brechna, who, although deeply involved in magnet design work for the beam switchyard, found time also to design the magnet for the analyzer stations.

### **References**

- 1 P. Brunet, J. Dobson, M. J. Lee, and C. B. Williams, “Microwave Beam Position Monitors,” Tech. Note No. SLAC-TN-64-45, Stanford Linear Accelerator Center, Stanford University, Stanford, California (July 1964).
- 2 M. J. Lee, “The Effect of Rotation of a  $TM_{120}$  Cavity on the Amplitude and Phase of the Beam-Induced Signal,” Tech. Note No. SLAC-TN-64-66, Stanford Linear Accelerator Center, Stanford University, Stanford, California (October 1964).
- 3 R. Bergere, A. Veysiere, and P. Daujat, *Rev. Sci. Instr.* **33**, 1441 (1962).
- 4 L. H. Johnston, J. Faust, W. Pierce, and M. Stangenes, *IEEE Trans. Nucl. Sci.* **NS-14**, No. 3, 1106 (June 1967).
- 5 O. Altenmueller and P. Brunet, “Some RF Characteristics of the Beam Phase Reference Cavity,” Tech. Note No. SLAC-TN-64-51, Stanford Linear Accelerator Center, Stanford University, Stanford, California (September 1964).

- 6 R. S. Larsen and H. A. Woods, *IEEE Trans. Nucl. Sci.* NS-12, No. 3, 862 (June 1965).
- 7 R. S. Larsen, "Design of Beam Position and Charge Monitoring Circuits for the Stanford Two-Mile Accelerator," Rept. No. SLAC-63, Stanford Linear Accelerator Center, Stanford University, Stanford, California (May 1966).
- 8 B. de Raad, "Some Visual Beam Observation Methods of Interest for the Beam Switchyard," Tech. Note No. SLAC-TN-64-4, Stanford Linear Accelerator Center, Stanford University, Stanford, California (January 1964).
- 9 D. Reagan, *Rev. Sci. Instr.* 37, 1190 (1966).
- 10 SLAC Staff, "Consolidation of Results of Preliminary Beam Tests with Sectors 1 and 2," Rept. No. SLAC-50, pp. 66, 69, Stanford Linear Accelerator Center, Stanford University, Stanford, California, (September 1965).
- 11 See, for example, J. J. Livingood, *Principles of Cyclic Particle Accelerators*, Van Nostrand, Princeton, New Jersey, 1961.
- 12 S. Penner, *Rev. Sci. Instr.* 32, 150 (1961).
- 13 M. J. Lee and A. W. Burfine, "Magnetic Field Measurements and Energy Calibration of the Beam Analyzing Station Spectrometers," Tech. Note No. SLAC-TN-65-21, Stanford Linear Accelerator Center, Stanford University, Stanford, California (1965).
- 14 M. J. Lee, "Some Calculations on the Aluminum SEM Foils," SLAC Internal Memorandum, Stanford Linear Accelerator Center, Stanford University, California (1965).
- 15 M. J. Lee, "An Ion Chamber in Air for the Beam Analyzing Station Interlocks," Tech. Note No. SLAC-TN-65-30, Stanford Linear Accelerator Center, Stanford University, Stanford, California (April 1965).