

TRIGGER SYSTEM

A. Barna, E. J. Faust,
K. W. Henderson, and K. B. Mallory, Editor

The trigger system must provide appropriate timing signals to the injector, the RF drive system, the klystron modulators, the beam transport system, the end-station equipment, and the data-transmission system. Two independent timing functions are to be provided: one is *pulse-rate selection* and the other is *synchronization*—the adjustment of the relative timing of various devices with respect to a single master trigger pulse.

14-1 System design (KBM)

Principles of operation

Three major operational requirements govern the general philosophy of the trigger system design: low jitter, variable repetition rates, and protection and maintenance routines.

First, the relative jitter of the outputs of components (gun, klystrons, etc.) contributing to a beam pulse must be 15 nsec maximum. The synchronization of different trigger pulses must, therefore, be accurate, stable, and independent of the repetition rate of the beam or of the number of klystrons in use.

The second requirement is that the accelerator shall normally operate at repetition rates from 60 to 360 pulses/sec and that beams at lower rates shall be available for special experiments. Operation with interlaced beams of different energy and intensity is also required. It is, therefore, necessary that various pieces of equipment be driven at different repetition rates.

The small jitter and flexibility of repetition rate are obtained by using a single, master clock signal at 360 pulses/sec from which all synchronization is derived, and by using slow gating signals at each piece of equipment to determine which pulses in the 360-pulses/sec clock train are used.

The third requirement is that certain protection, standby, and maintenance functions must be provided through the trigger system:

1. In case of a gas burst in an accelerator section, the trigger must be removed from the corresponding klystron modulator.
2. In case of serious deterioration of vacuum or failure of certain water circuits, the beam must be turned off promptly by removing the trigger to the injector. The beam must also be shut off when the personnel protection interlocks are interrupted.
3. In case of excessive radiation, the beam must be turned off.
4. For phasing, the accelerator structure must be kept at normal operating temperature (by supplying RF power to the section) while the beam-induced signal is observed.
5. Newly installed klystrons must be tested without interfering with the beam operation.
6. Reserve klystrons must be warmed up and ready for operation to take the place of failures.

The three latter items are handled using an auxiliary, delayed trigger signal which does not coincide with the beam. The "delayed" trigger is 25–50 μsec later than the normal "prompt" trigger. The delay at successive sectors is staggered so as to prevent appreciable acceleration of stray electrons during the delayed pulse.

The protective circuits associated with the klystron and its modulator are described in detail in Chapter 15. These circuits are located in the instrumentation rack adjacent to each modulator and are provided as part of the actuation and measurement equipment, not as part of the trigger system.

Special circuits are provided to shut off the gun in case of excessive radiation, pulse-magnet malfunction, or other cause or symptom of undesirable beam loss. These circuits interact with the gun trigger through equipment described in Chapter 21.

SYSTEM LOGIC. A simplified diagram of the trigger system is shown in Fig. 14-1. The entire trigger system is slave to a clock composed of the sequence generator and the master trigger generator. The sequence generator, located

Figure 14-1 Trigger system block diagram.

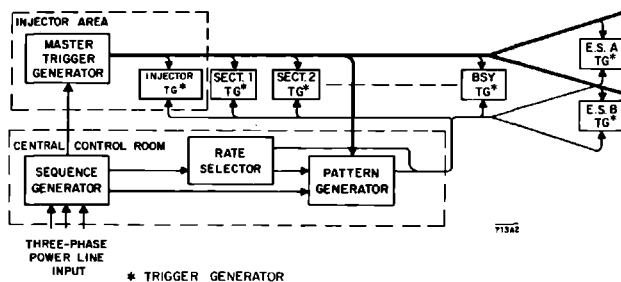

in central control, locks the master trigger generator to the 60-Hz line frequency and supplies gating pulses to the rate selector and pattern generator. The master trigger generator, located at the injector end of the klystron gallery, creates the 360-pulses/sec clock pulses which are transmitted to trigger generators located wherever trigger signals are required.

The pattern generator in central control generates for each piece of equipment a millisecond pulse "pattern signal" which determines whether the next clock pulse is or is not to be used. Each trigger generator uses the gating information from the pattern generator and the precise timing of the clock pulse from the master trigger generator to generate the appropriate output trigger pulses.

MASTER CLOCK AND MAIN DISTRIBUTION. The synchronization of all events associated with a given pulse of electrons in the accelerator is determined by clock signals from the master trigger generator. It operates at 360 Hz, locked to the power line frequency. The clock output is a train of pulse pairs consisting of a negative pretrigger followed 25 μ sec later by a positive main trigger pulse.

The clock output pulses are distributed by a 1 $\frac{1}{8}$ -in. diameter, high-velocity, low-loss coax line to trigger generators in each sector, in central control, in the switchyard, and in each end-station area. The main trigger line is isolated from the equipment by coupling transformers in the line and by gates and buffer amplifiers in the trigger generators. The trigger generators can be programmed to select the proper pulse rate and pattern for each piece of equipment.

Programming for multiple beams

As will be shown below, the patterns occasionally will be irregular during multiple-beam operation. The klystron modulators are designed to be operated at regular rates (60, 120, 180, or 360 pulses/sec). Special gating signals, called "rate signals," are synthesized at the rate selector in central control. These signals enable the trigger generator to furnish "delayed" trigger pulses with a small delay of, say, 25 μ sec, which fill in gaps in an irregular pattern but do not contribute unwanted acceleration energy to the beam.

In order to limit the range of regulation for power supplies and water systems, 60 pulses/sec was chosen as the minimum klystron operating rate (360 pulses/sec is the design maximum). It is evident that one can operate half the klystrons at 360 pulses/sec and the rest at 60 pulses/sec, thus producing two interlaced beams—one full-energy pulse followed by five half-energy pulses. A pulsed, magnetic deflection system for steering the beams to different targets was determined to be feasible and led to the multiple-beam concept.

A problem arises when one attempts the reverse situation: the case in which 60 pulses/sec are to be at half-energy and the remainder are to be at full energy. In this case, half of the klystrons are to skip one pulse out of

every six. With the best of regulators, the first RF pulse after the skipped one will not be of exactly the same magnitude as the others. In order to avoid skipping a pulse, a small pulse-position modulation was introduced to delay a modulator pulse for a few microseconds when it was not desired for acceleration. This “delayed” pulse occurs after the beam has passed, so that it cannot affect the electron energy, but it serves to keep the average power and the repetition rate of the klystron constant.

The pattern signals are described in detail below. Briefly, the desired pattern of beam pulses is set up within the pattern generator, and a set of selector switches connects each beam pattern to the equipment which contributes to that beam. The sum of all beam patterns required for a piece of equipment is its pattern signal.

The following additional features are required:

1. Provision must be made for resolving overlapping requests, i.e., two or more requests for the same beam pulse.
2. It must be possible to switch back and forth between any two beams of the same energy but differing in other characteristics such as pulse length, intensity, and repetition rate.
3. It must be possible to program klystrons, pulse magnets, experimental equipment, etc., for a new beam before prior experiments are terminated.

It has been determined that it can take as long as 2 hours to set up a high-energy run after a low-energy run. Most of this time may be eliminated if the new beam is programmed while the former experiments are still in progress, and tuned up by stealing a few pulses per second from the prior experiments.

USE WITH MULTIPLE BEAMS. Since a pattern signal impulse is transmitted to a piece of equipment only when it is to be triggered, it is possible to turn on different combinations of klystrons or steer the beam by means of the pulse magnets to different targets on successive pulses. Each different program of pieces of equipment to be triggered for a given pulse can be considered the program of a separate beam. Consider the following example, chosen to illustrate pattern signal logic—not a real experiment. A spark chamber operating in area B requires 60 pulses/sec at 10 GeV, but there must be no beam pulse in the accelerator $1/360$ sec before, in order to reduce the probability of stray background trails. The experimenters in area A desire 20 GeV, using every available leftover beam pulse.

It is clear that the entire accelerator must contribute to four successive beam pulses to area A, the entire accelerator must be off for the next pulse, and half the accelerator will then contribute to one beam pulse for area B. Typical pattern signals for this type of operation are shown in Fig. 14-2.

The pulse patterns are irregular; this is a natural result of using multiple beams. However, the klystrons will be triggered by the “delayed” trigger when the pattern signal is off and thus will operate at a regular rate (in this example, 360 pulses/sec for all klystrons).

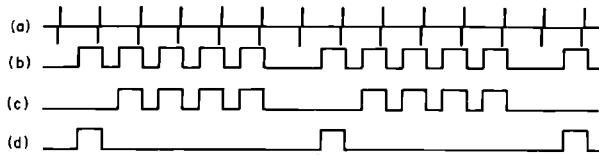

- (a) Clock pulses
 (b) Pattern signals for Injector and Sectors 1-15
 (c) Pattern signals for Sectors 16-30, Target Area A trigger generator and Pulse Magnet A
 (d) Pattern signals for Target Area B trigger generator and Pulse Magnet B

713a1

Figure 14-2 Pattern signals for a 60-pulses/sec beam at 10 GeV to area B, following a 60 pulses/sec "null beam," with the remaining beam pulses at 20 GeV to area A.

In order to produce the desired pattern signals, it is first necessary to determine which beams are desired. In the example above, area A is willing to use all leftover pulses; it is "requesting" a 360 pulses/sec beam. Area B is requesting a 60-pulses/sec beam, but it is also requesting no beam on the preceding pulse. Such a required "null beam" must be programmed just like any other beam.

Since it is impossible to handle two different beams during one pulse, it is necessary to cancel area A's request for a 20-GeV beam whenever area B requests its null beam or its 10-GeV beam. A "priority circuit" sorts out the requests to determine which beam shall be delivered on each machine pulse. The resultant output signals are the "beam pattern signals" which are then used to generate the pattern signals for the equipment. The purpose of the priority circuit is twofold: (1) It provides a very simple means of generating the irregular beam pattern signal for area A, and (2) it allows area A to receive all pulses automatically any time B interrupts experiments and cancels its requests. There need be no wasted pulses; an area willing to accept all leftover pulses will, indeed, get a beam pulse, of the proper energy, every time another experiment is not using the beam.

Trigger generators

"STANDARD" TRIGGER GENERATOR CHANNEL. A typical trigger generator channel is diagrammed in Fig. 14-3. Its operation is as follows.

A sampling device couples a portion of the clock output from the main trigger line to each trigger generator. A diode network blocks low-level noise from the trigger line and separates the positive main trigger pulse from the negative pretrigger pulse.

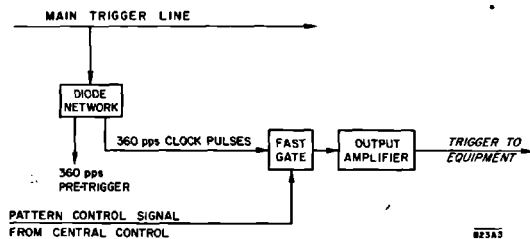

Figure 14-3 Standard trigger generator channel.

The main trigger is fed through a fast gate controlled by the two-state pattern signal sent from central control. If the pattern signal is "on," a trigger signal is passed on to the equipment. If the pattern signal is "off," no trigger output will exist. A delay network, if required, produces the proper timing with respect to the beam. A final amplifier produces a trigger signal of 10-volt amplitude, 50-nsec rise time, and 400- μ sec duration which is delivered via a 50-ohm cable to a 50-ohm input in the equipment to be triggered.

This output level is the nominal standard for all trigger generators. As previously stated, the output pulse pattern is determined entirely by the pattern control signal from central control. It may be completely arbitrary—anything from a single pulse on demand, one pulse per year, to 360 pulses/sec, any combination of bursts of pulses, skipped pulses, regular rates, etc. It is at central control that these patterns must be generated. The local generator is strictly a slave to its pattern control signal.

SECTOR TRIGGER GENERATOR. Although the sector trigger generator is basically a group of standard trigger channels as described above, the modulator trigger is handled somewhat differently. The klystron modulators must operate at regular rates of 60, 120, 180, or 360 pulses/sec in order to satisfy specifications on pulse-to-pulse stability. For this equipment, therefore, the arbitrary pulse patterns required for multiple-beam operation are provided by using the pattern control signal to shift the timing of the modulator triggers. When the pattern signal is "on," the modulator is triggered by "prompt" pulses coincident with the beam. When the pattern signal is "off," the modulator is triggered by "delayed" pulses, just after the beam has passed by. The overall pattern is, therefore, a uniform pulse rate with a small pulse-position modulation. The "prompt" pulses contribute to the beam, the "delayed" pulses do not. (A different delay is used at each sector in order to minimize the energy to which stray electrons can be accelerated during the "delayed" pulse.)

In addition to the normal "accelerate" trigger output, which may contain prompt and delayed pulses according to the requirements for multiple beams, a "standby" output containing only delayed pulses is required for klystrons being held in reserve, cycling after gas bursts, being tested, phased, etc. The

standby output is controlled by the rate selector setting only; it is not affected by the pattern signal.

The drive sub-booster must provide delayed as well as prompt drive pulses for the klystrons. To keep its phase shift constant, it delivers 360 pairs of drive pulses per second no matter what rate the klystron modulators use. Hence, neither rate setting nor pattern control signal affects sub-booster operation.

In order to compensate for beam loading (discussed in Chapter 5), a 0–1 μsec remotely adjustable delay, common to the modulator and sub-booster pulses, is provided for each sector. This allows compensation for the energy droop of the beam which occurs within each pulse, at high beam current.

The automatic phasing equipment requires both the prompt and the delayed pulse at 60 pulses/sec. The data-handling system requires the ungated 360-pulses/sec standard trigger only.

Analysis of trigger system delays

The various delays which must be considered in determining the synchronization relationships of the trigger system are discussed below, and shown in Figs. 14-4a through d. Delays are designated by the symbol τ plus a subscript for identification. Compensations are designated by the symbol T plus a subscript.

The sum of all the necessary delays (τ_M, τ_T, \dots) plus the fixed compensation T_C is a minimum of $L/c + l/c + 3.26 \mu\text{sec}$ and a maximum of $L/c + l/c + 3.96 \mu\text{sec}$. T_F allows optional insertion of up to $0.775 \mu\text{sec}$ additional delay so that the RF pulse will fill the accelerator exactly $L/c + l/c + 4.0 \mu\text{sec}$ after the trigger pulse starts down the main line.

1. *Main line delay* = τ_M . The trigger signal travels from the main trigger generator to the individual sector in a time $\tau_M = L/0.921c$, where L is the distance to the sector and c is the velocity of light. The clock signal at Sector 30 is delayed $0.843 \mu\text{sec}$ more with respect to the electron beam than the clock signal at Sector 1.
2. *Compensation for main line delay* = T_C . The compensation varies from $1.00 \mu\text{sec}$ at Sector 1 to $0.16 \mu\text{sec}$ at Sector 30. The trigger signal is arranged to arrive at the sector trigger generator $3.00 \mu\text{sec}$ before the beam arrives at a point directly below.
3. *Trigger generator delay* = τ_T . A delay of $0.20 \mu\text{sec}$ is allowed through the gates and power amplifiers in the trigger generator.
4. *Sector trigger distribution delay* = τ_d . The delay in the sector distribution cables is $\tau_d = l/0.67c$, where l is the variable distance from the sector trigger generator to the klystron fiat racks.
5. *Sector distribution compensation* = T_d . Compensation for the low group velocity is accomplished by supplying increased cable lengths to the first few fiat racks. The excess delay is $0.16 \mu\text{sec}$.

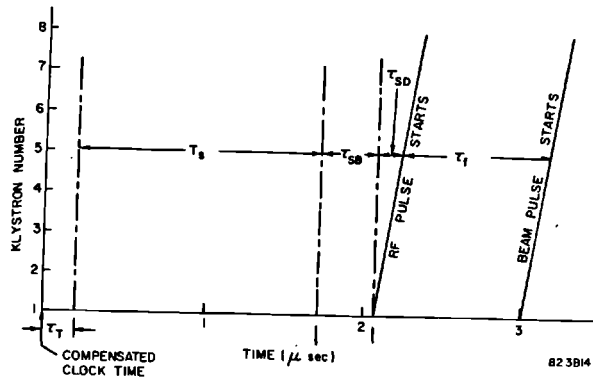
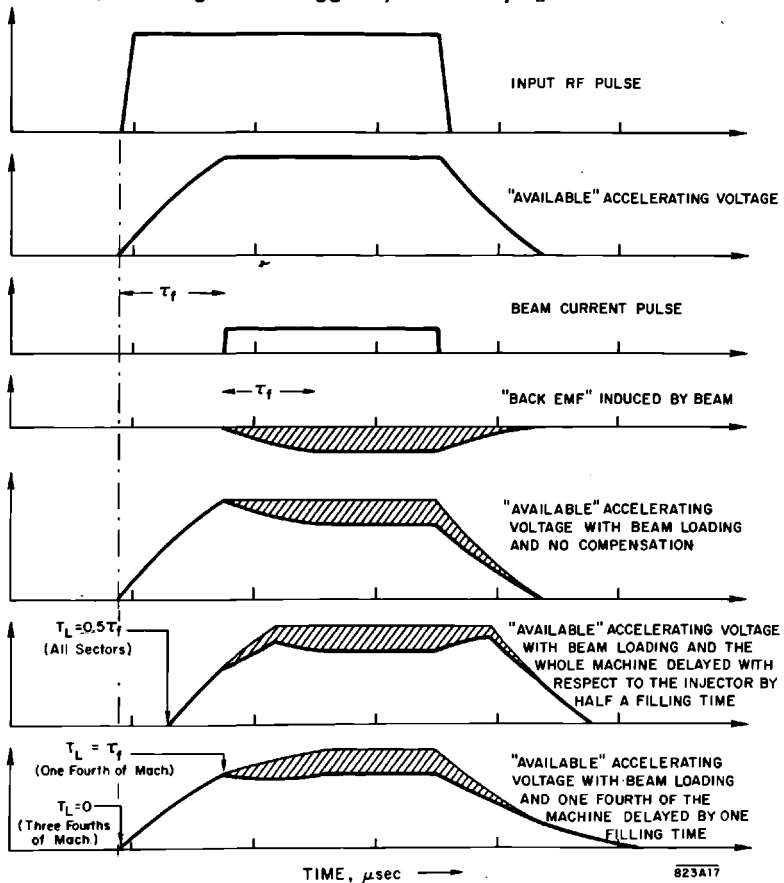

Figure 14-4c Intrasector timing diagram showing trigger system delays and compensations $T_T, T_S, T_{SD}, T_{SB}, T_f$.

Figure 14-4d Two first-order approaches to beam-loading compensation, showing use of trigger system delay T_L .



6. *Modulator delay* = τ_m . A delay of 0.1 to 1.0 μsec (including up to 0.40 μsec thyratron anode delay) must be allowed. The compensation is accomplished in T_F .
7. *Fiat rack compensation* = T_F (see Chapter 15). A 0–0.775- μsec delay (steps of 400, 200, 100, 50, and 25 nsec) is provided at each fiat rack to compensate for thyratron anode delay which differs from one thyratron to another and varies during the life of any individual thyratron.
8. *Modulator rise time delay* = τ_r . The modulator rise time is taken to be 0.70 μsec . It is assumed that there may be individual differences between modulators of $\pm 0.10 \mu\text{sec}$.
9. *Filling time* = τ_f . The filling time of the accelerator input waveguide is about 0.10 μsec and of the accelerator proper, 0.83 μsec .
10. *Subdrive line delay* = $\tau_{SD} = l/c$. The group velocity of the subdrive line is taken to be virtually equal to the velocity of light. There is, therefore, no excess delay in the subdrive line.
11. *Sub-booster modulator delay* = τ_{SB} . The delay in the trigger and driving circuit of the sub-booster modulator is assumed to be greater than 0.10 μsec but less than 0.50 μsec .
12. *Sub-booster timing adjustment* = T_S . In order to make the sub-booster and the main klystron pulse overlap properly, it is necessary to satisfy the equation:

$$T_F + T_d + \tau_d + \tau_m + \tau_r = T_S + \tau_{SB} + \tau_{SD}$$

The equation is satisfied by adjusting T_S , which is composed of a fixed delay of 1.30 μsec plus a variable 0.0–0.775- μsec delay identical to T_F . On the average, all of the above delays add up to $L/c + l/c + 3.10 \mu\text{sec}$.

13. *Beam-loading adjustment* = T_L . The beam-loading adjustment for each sector is remotely controlled from central control. The minimum delay is labeled 0.0 μsec ; the maximum delay is labeled 1.0 μsec .
14. *Standby delay* = T_D . At each sector, the standby delay is fixed at a value between 25 to 50 μsec . As previously explained a different standby delay is used in each sector.

Beam-loading compensation

The reduction in electron energy and deterioration in spectrum width which are caused by beam current loading are discussed in Chapter 5, in the section dealing with beam characteristics. Figure 5-27 illustrates the development of a high-energy tail on the spectrum as the beam current is increased.

A fair degree of compensation for the deleterious effects of beam loading may be achieved by using the trigger system delay T_L . Two simple approaches are illustrated in Fig. 14-4d. The heavy lines in the lower three diagrams indicate the magnitude of the available accelerating voltage. Some compensation is afforded by delaying the whole machine with respect to the injector. A better solution, however, is to delay one or more sectors by approximately one filling

time. Since the rise of the available voltage pulse approximates a truncated exponential and the rise of the "back emf" is roughly parabolic, perfect compensation cannot be achieved by varying a single parameter. Nevertheless, the spectrum may be considerably improved, as illustrated in Fig. 5-28.

Signal waveforms

The system uses two types of signals: trigger pulses and programming pulses. The trigger pulses have nominal length 400 nsec, rise time 20 nsec, and timing precision ± 5 nsec. The programming pulses have nominal length 1000–1700 μ sec, rise time 30 μ sec, and timing precision 50 μ sec. Trigger pulses are transmitted on 50-ohm coaxial cables, at a level of 10 V (except in the main distribution system). Details of the ± 400 -V output pulse train from the master trigger generator are given in Fig. 14-5. Programming pulses are transmitted on balanced telephone pairs, at a level of about 10 V into 1000 ohms. Examples are shown in Fig. 14-6.

Two types of programming pulses have been distinguished: rate signals and pattern signals. The rate signals originate in the sequence generator and rate selector and have rates of 60, 120, 180, and 360 Hz. They are used primarily to trigger equipment that must operate at a uniform rate (such as klystron modulators) regardless of the specific repetition rate of a beam. They are centered about the beam pulse as shown in Fig. 14-6c.

The pattern signals are associated with a particular beam or group of beams and may be irregular—a pattern at 300 pulses/sec would contain five pulses at 360 Hz, followed by a gap of twice the normal interpulse interval.

The pattern signal is used to gate both the prompt and the delayed klystron trigger pulses; it, therefore, overlaps the beam pulse, Fig. 14-6a, by about 100 μ sec. It also is used to switch dc levels in the positron phase shifters and to trigger the pulsed magnets in the switchyard; these circuits must be allowed

Figure 14-5 Master trigger generator, output pulse

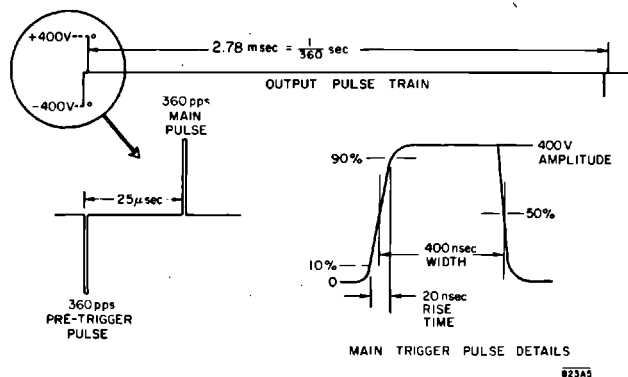

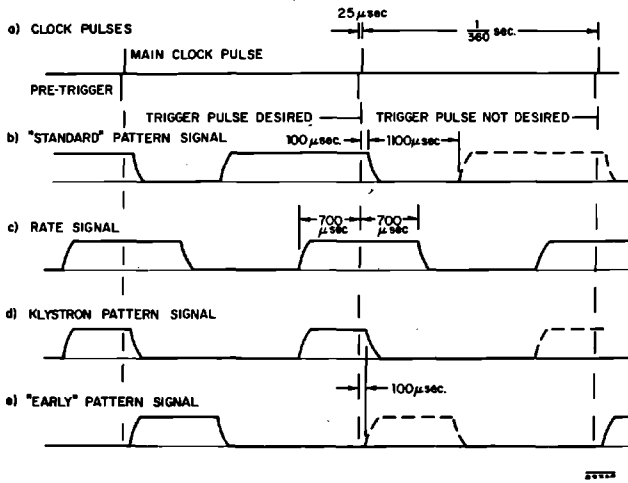

Figure 14-6 Typical pattern signals.

an advance warning of about 1500 μsec . The normal pattern will, therefore, be a chopped signal of Fig. 14-6b. It is always off from the time 100 μsec after the beam to the time 1200 μsec after the beam, and it is on for the remaining interval if the pattern calls for the use of the next pulse. The signal duration is thus about 1677 μsec for each beam pulse required.

The pattern signal transmitted to each sector trigger generator for the klystrons is first combined with the "rate signal," Fig. 14-6c, for that sector at CCR. Since the rate signals from the sequence generator are of shorter duration than the normal pattern signals, the resultant "klystron pattern signals" will be shortened to approximately 1-msec duration, as shown in Fig. 14-6d. They must also overlap the beam pulse by 100 μsec .

For certain functions, an "early" pattern signal is required. This signal consists of pulses starting 100 μsec after the preceding beam pulse and continuing for 1100 μsec , as shown in Fig. 14-6e.

14-2 Description of system components (EJF)

The trigger system has four groups of components: the clock, the distribution system, the trigger generators, and the programming equipment.

The clock produces main trigger clock pulses at 6 times line frequency (nominally 360 Hz). The special distribution system transmits the clock pulses to the trigger generators where they are gated by the programming pulses to yield trigger pulses at the appropriate repetition rate for each piece of equipment. The programming pulses thus determine which pieces of equipment are operated for each beam pulse; they are controlled by the operator at the pattern generator in central control.

Master clock

Associated with the clock are the sequence generator, the master trigger generator, and the comparator.

SEQUENCE GENERATOR. The functions of the sequence generator are (a) to produce a 360 pulses/sec pulse train to drive the master trigger generator (the source of "clock" pulses) and (b) to produce the six different phases of 60-pulses/sec pulses needed to form the rate pulses.

Figure 14-7 shows the time relationships of the input and output waveforms of the sequence generator. The six, equally spaced phases of 60-pulses/sec output pulses are formed from the positive-going and negative-going zero crossings of the input. These sine waves of input current are changed to voltage pulses by the saturating transformers, of which the cores have the property of becoming quickly saturated with flux as the magnetizing current increases. Inductors in series with each transformer limit the surge current during the time when the core is saturated and the transformer impedance is negligibly low. The output pulses are properly channeled by diodes.

Figure 14-7 Sequence generator waveforms and schematic.

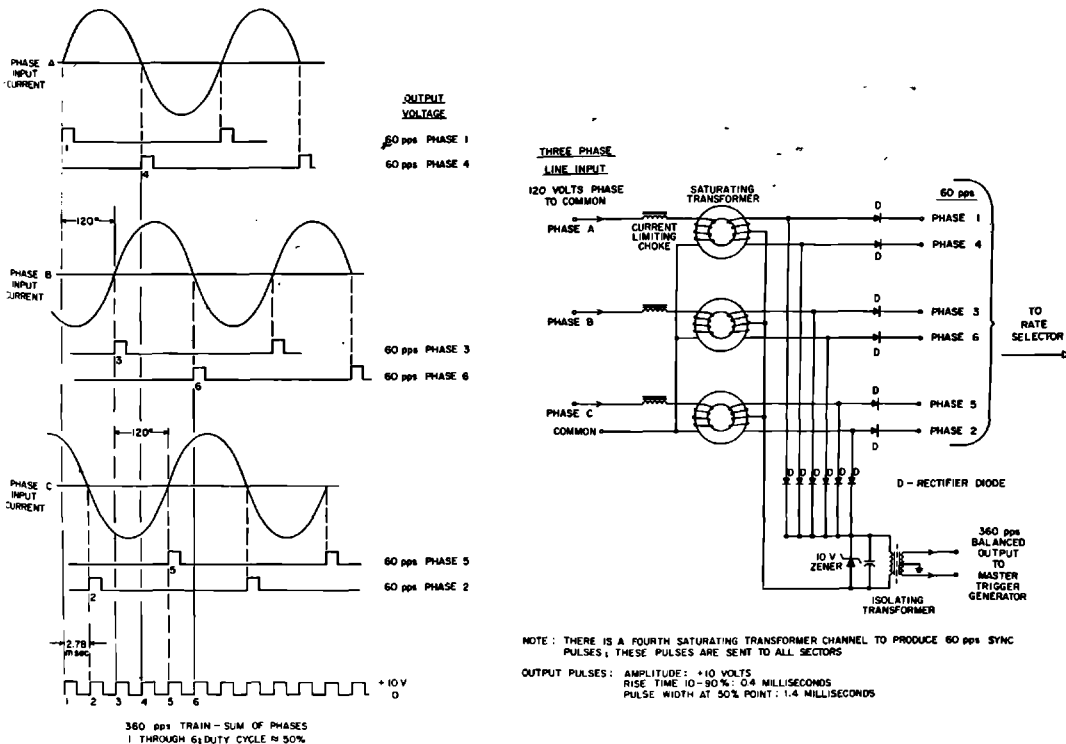

An important function that the sequence generator fills is the locking of the output pulses to the incoming 60-cycle line frequency. (These pulses define the timing of the "clock" pulses for the machine.) This technique is useful in eliminating noise caused by beat frequencies that would be present with a system not locked to line frequency.

There is a high degree of reliability obtained by using the three-phase line as an input. In the event of the failure of any phase, a filter in the master trigger generator has a sufficiently long time constant to maintain a train of output clock pulses from the master trigger generator. This guards against a sudden dumping of the entire 245-modulator power load.

The use of three sequence generators is a further aid to reliability. Each generator supplies rate signals for one-third of the machine, another safeguard against a sudden loss of the entire modulator power load. Each sequence generator also supplies pulses to one of the three master trigger generators; thus, the system for generating clock pulses is triply redundant from power line input to clock pulse output.

MASTER TRIGGER GENERATOR. The master trigger generator (MTG) is the source of precisely timed pretrigger and main clock pulses for the trigger system. The block diagram, Fig. 14-8, shows how the master trigger generator converts the slow-rising, 360-pulses/sec pulses from the sequence generator into fast, low-jitter, positive and negative output pulse pairs.

The input pulses are first carefully filtered with a 360-Hz, band-pass filter into a relatively pure and jitter-free sine wave. A phase shifter retards the phase of the wave to ensure that the clock pulses derived from this wave will be centered relative to the input pulses. A pulse shaper then converts the 360-Hz sine wave to a negative 360-pulses/sec pulse train. This output splits into an undelayed and a delayed channel and is regenerated and amplified to form the pretrigger and main trigger pulses. These pulses are combined in the output pulse transformer and sent down the main trigger line.

COMPARATOR. Failure of the sequence generator or the master trigger generator could produce a complete system failure. Sudden failure of the master

Figure 14-8 Block diagram of master trigger generator.

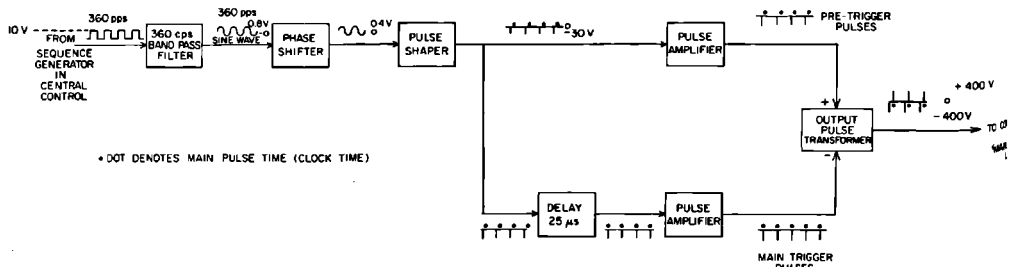

clock when all the klystron modulators are in operation would produce significant power line transients which are to be avoided. Three redundant sequence generators and MTG's are furnished. The comparator monitors the outputs of the three MTG's and switches a reserve MTG to the main trigger line when the active one fails.

The basic requirements for the comparator are that it will

1. detect a missing pulse from a MTG;
2. detect an extra pulse from a MTG;
3. operate a transfer switch when such a fault occurs in the MTG on the line;
4. have a limited recycling capability.

A missing pulse fault condition is defined to exist when no pulse occurs within 3.0 msec of the previous clock pulse. An extra pulse fault condition exists when a pulse occurs within 2.5 msec after the previous clock pulse.

Figure 14-9 shows a block diagram of one of the monitor circuits and indicates typical waveforms. Only the positive clock pulse is monitored. The clock pulse triggers an asymmetrical multivibrator which has a long dead time (2.5 msec) followed by a short active time (0.5 msec) during which it may be triggered again. Normally a clock pulse arrives after 0.28 msec of active time and resets the multivibrator. An extra pulse which arrives too soon cannot reset the multivibrator. If a clock pulse does not arrive during the short active interval, the multivibrator resets itself automatically after 0.5 msec of active time.

Figure 14-9 Monitor circuit for comparator.

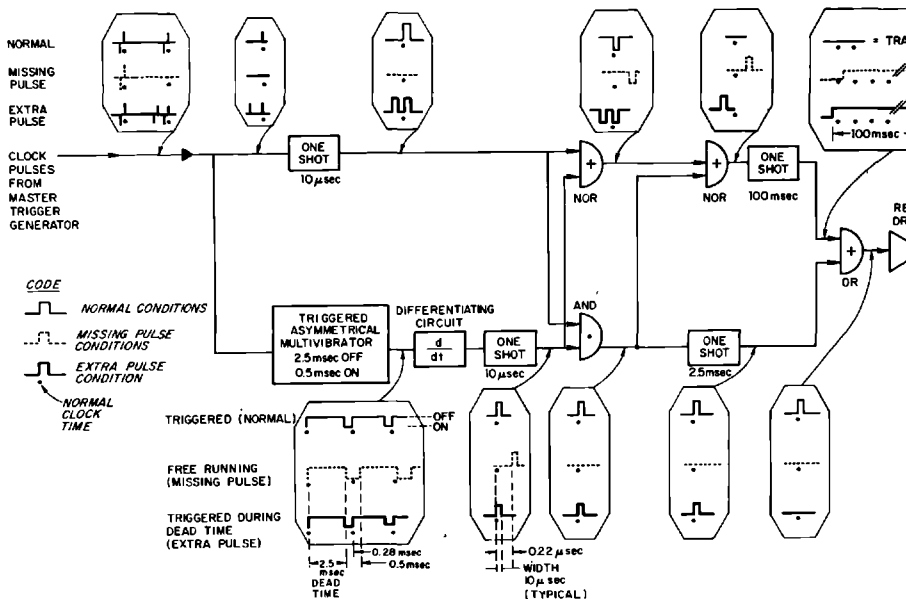

There are three conditions to consider: (1) normal—no faults; (2) missing pulse; and (3) extra pulse.

Referring to Fig. 14-9, and *assuming the normal condition* it is seen that the multivibrator is off for the standard "dead time" of 2.5 msec, at the end of which it automatically turns itself on. The arrival of a clock pulse 0.28 msec later turns the multivibrator off again. The differentiating circuit produces a narrow pulse coincident with turnoff, which in this case is at clock time. The one-shot multivibrator stretches this narrow pulse to 10 μ sec, which is sufficiently wide for accurate summing in the gates. The AND gate receives two coincident clock time pulses; it, therefore, transmits a pulse at clock time. NOR₁ (an inverting OR gate) also receives both pulses and sends out an inverted replica of the input pulses. NOR₂ algebraically adds the pulses from the AND gate and NOR₁. Because these are coincident pulses of opposite polarity, zero output results. The 100-msec one-shot inhibit signal is, therefore, not triggered in the normal mode. The 2.5-msec one-shot, however, is triggered regularly at 360 pulses/sec. These pulses pass through the OR gate and relay driver to hold the relay contacts closed.

In the *missing pulse condition*, the absence of a trigger pulse at clock time causes the narrow pulse in the asymmetrical multivibrator waveform to continue past clock time, until the multivibrator turns itself off. The differentiating circuit now produces a pulse 0.22 msec later than normal. Tracing this late pulse through the AND gate, it is seen that there can be no output because there is only one input signal. However, the NOR₁ gate does transmit the late pulse, as does the NOR₂, so that the 100-msec inhibit signal is initiated. This allows the relay to drop out and causes the comparator to switch to another MTG.

In the *extra pulse situation*, the asymmetrical multivibrator operates normally, because the extra pulse arrives at a time when the multivibrator is insensitive to triggering. The AND gate receives two simultaneous inputs at clock time and, therefore, transmits an output pulse. NOR₁ sends out an inverted double pulse, the clock pulse, and the extra pulse. NOR₂ sends out only the extra pulse, because the erect and inverted clock pulses cancel each other. The extra pulse initiates the 100-msec inhibit signal which stops transmission of the 2.5-msec pulses through the OR gate, causing the relay contacts to open. After the 100-msec interval, the relay closes again until another fault occurs. The transfer switches are fast enough to ensure that no clock pulses are lost during transfer.

Distribution system

The clock output pulses are distributed by a high-velocity, low-loss, coaxial line to trigger generators in each sector, at the injector, at central control, in the switchyard, and in each end-station area and physics laboratory.

MAIN TRANSMISSION LINE. The electron beam specifications require that the pulse-time jitter shall be ± 15 nsec maximum. Assuming that some jitter is

introduced in modulators and in amplifiers in the trigger system, a specification of about ± 5 nsec must be placed on the transmission system between the master clock and the trigger generators. With good discriminators, it is possible to hold 5-nsec jitter with about 50-nsec rise time of the input pulse to the trigger generators.

The clock pulse must arrive at every sector somewhat ahead of the beam pulse in order to turn on the klystron modulators. It was decided that the clock pulse should arrive at every sector exactly the same amount in advance (3.0 μ sec). An adjustable delay at each sector then triggers the equipment at each sector at the correct time.

The beam requires approximately 10.2 μ sec to travel 10,000 ft. In a cable, it will take a clock pulse slightly longer to travel the same distance. With an air dielectric cable, the difference in transit time between beam and clock pulse is negligible. With a solid polyethylene dielectric, the propagation velocity of the clock pulse is about two-thirds the velocity of the beam, and the transit time of the clock pulse will be 5 μ sec greater. A compensating delay must, therefore, be inserted at the first sector (and a proportionately reduced delay at later sectors) in order to trigger the equipment at the proper moment.

It is difficult to introduce a delay as great as 5 μ sec without introducing more than 5-nsec jitter. It is uneconomical to use a cable with $v = c$ in order to eliminate this delay. The practical solution is to use a cable with moderately high velocity, $v = 0.91c$, which introduces 1.0- μ sec extra transit time for the trigger pulse. The 1.00- μ sec delay required at Sector 1, the 0.97- μ sec delay required at Sector 2, etc., may be introduced by extra delay cables that degrade the rise time of the pulse to just such an extent that the received pulse is of the same quality at every sector.

For most cables useful in pulse transmission, attenuation below approximately 1000 MHz is due mainly to skin-effect losses and varies as the square root of frequency.¹ For such cables, the output response to a step-function input has a rise time that varies as the square of the attenuation at a given frequency.

The 0-50% rise time, T_0 , is given by the formula

$$T_0 = 4.56 \times 10^{-12} A^2 l^2 \text{ sec}$$

where A is attenuation in decibels per unit length at 1 GHz, and l is the length of the cable.

Cables of different sizes or types were compared for cost vs loss. For a 50-nsec rise time, the total attenuation Al is 105 dB. Therefore, the cable must have a loss at 1 GHz of 1.05 dB/100 ft or less. The least expensive cable which approached this requirement was found to be a $1\frac{3}{8}$ -in. diameter, Helix cable. This cable has a velocity of $0.91c$ and requires some compensation.

TAKEOFF TRANSFORMERS (AB). The purpose of the takeoff transformers² is to provide timing pulses for the trigger generators without appreciably disturbing the pulses propagated along the main trigger line.

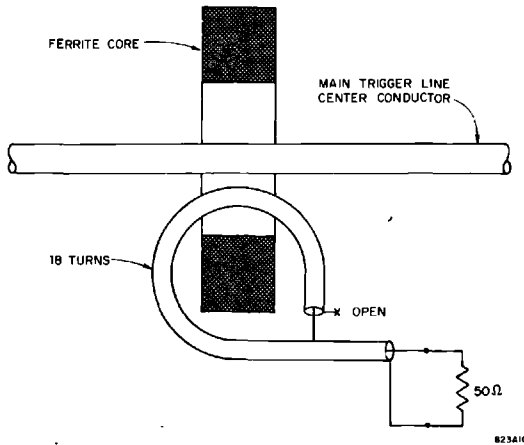

Figure 14-10 Schematic diagram of takeoff transformer.

A current transformer has been designed with the center conductor of the 50-ohm main trigger line as primary; the secondary winding consists of 18 turns of coaxial cable on a 1-in. ferrite core. This cable is terminated with its characteristic impedance of 50 ohms at the far end (see Fig. 14-10).

Measurements of the transient response show a 10–90% rise time of 2 nsec with 20% overshoot and ringing. The frequency response is down by 3 dB at 30 kHz and at 115 MHz.

The series impedance is reflected by the transformer into the main trigger line. The pulse height at the last sector is 87% of that at the first sector, resulting in takeoff voltages of 22.5 to 19 V along the entire accelerator for a MTG output voltage of 400 V.

Trigger generators

A number of different trigger generators are used, of which the outputs are determined by the requirements of the local equipment to be triggered. The most specialized trigger generators are to be found in the klystron gallery, where the requirements are fixed. The least specialized trigger generators are to be found in the research area where the requirements are frequently changed and where the experimenters are accustomed to providing their own gating and delay circuits.

The sector trigger generator is described in detail below; the other trigger generators use similar circuits, stripped down to the essential requirements.

SECTOR TRIGGER GENERATOR. The sector trigger generator must perform the following functions:

1. Trigger the sub-booster modulator at a constant, double 360-pulses/sec repetition rate, i.e., a pair of 360-pulses/sec pulses spaced 25–50 μsec apart.
2. Trigger the main modulators at a regular rate; specifically, 60, 120, 180, or 360 pulses/sec.
3. Deliver a regular or irregular train of “prompt” pulses to the main modulators on demand. (These pulses are timed so that the modulator output will accelerate the beam.)
4. Deliver a regular or irregular train of “delayed” or standby pulses to the main modulators to fill in gaps in the train of “prompt” pulses, thus satisfying requirement (2) above. These pulses are timed late, so that the modulator output will not accelerate the beam.
5. Deliver pulses to components or subsystems as follows: (a) 60-pulses/sec “prompt” and “delayed” pulses to phasing system; (b) 360-pulses/sec pulses to beam monitor equipment; and (c) 360-pulses/sec pulses to data-handling system.

In addition to the above requirements, the sector trigger generator must also perform the essential function of delaying modulator pulses as noted earlier.

Figure 14-11 is a block diagram of the sector trigger generator. Its input is a train of positive 360-pulses/sec “clock” pulses supplied by the MTG via the main trigger line and the sector takeoff tee.

The pulses coming off the tee are exact replicas of the clock pulses on the main trigger line except that they are reduced in amplitude from 400 to 20 V. The negative pretrigger pulse is shunted to ground by a diode. The remaining +20-V, 360-pulses/sec pulses (clock pulses) are passed through a pulse transformer that matches the 200-ohm impedance of delay T_C to the 50-ohm line. Delay T_C compensates for the slowness of the main trigger line relative to the electron beam, varying the amounts of delay in successive sectors in order to achieve synchronism.

The pulses leaving T_C are fanned out into three paths: (1) through delay T_D to produce “delayed” pulses, (2) through delay T_L to produce “prompt” pulses that are corrected for beam-loading effects; or (3) to synchronize most of the accessories, i.e., the phasing pulses, the data equipment pulses, and the beam monitoring pulses.

The sub-booster modulator trigger pulses are formed by combining prompt and delayed pulses in the OR₁ gate. These pulses are delayed by T_S , amplified to 40-V pulses, and sent out.

The “accelerate” trigger pulses for the main modulators are formed by combining prompt and delayed pulses in the OR₂ gate, but the process is a bit more complex. The prompt pulses are gated by pattern pulses in AND₁; there can be no transmission of “prompt” pulses through AND₁ without the simultaneous appearance of a pattern pulse. Therefore, the output of AND₁ is, in general, an irregular train of prompt pulses corresponding to the pattern

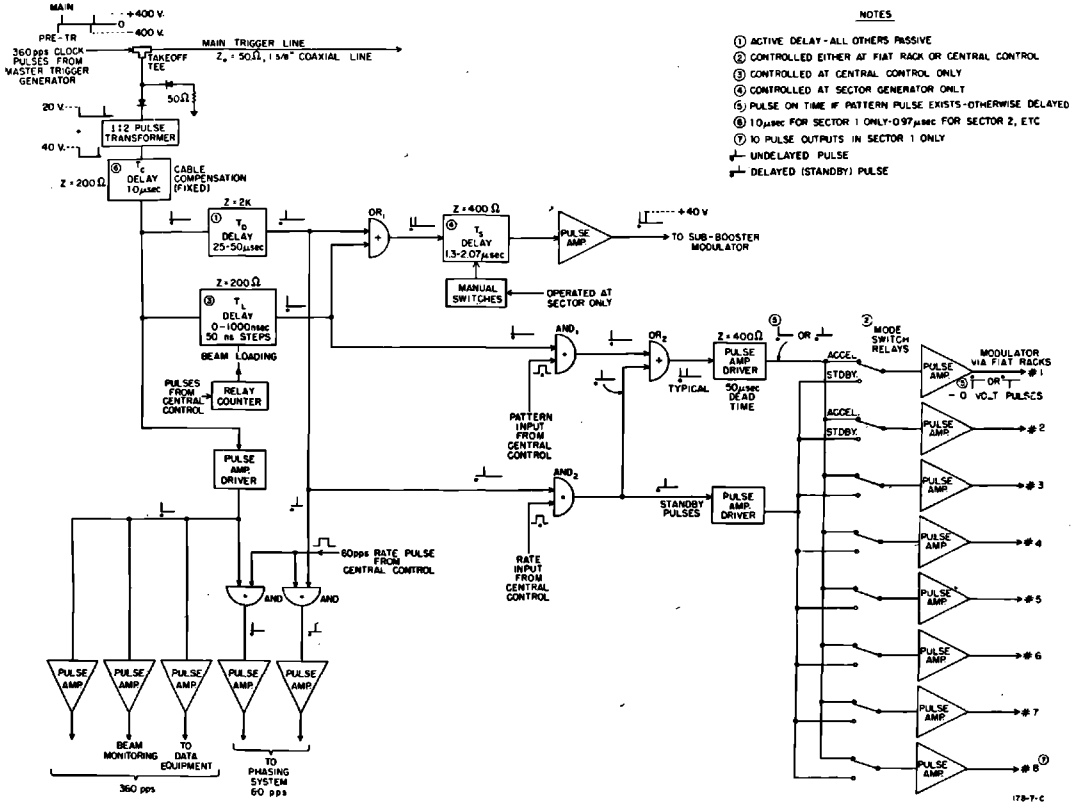

Figure 14-11 Block diagram of sector trigger generator.

pulse train. The AND₂ gate combines delayed pulses and rate pulses such that its output is a train of delayed pulses identical to the rate pulse train. The two outputs from AND₁ and AND₂ are then summed in the gate OR₂. When “prompt” and “delayed” pulses occur within 50 μsec of each other, the delayed pulse is suppressed in the pulse amplifier driver.

The output is an irregular pulse train which will, in general, have prompt and delayed pulses in various combinations. These pulses pass through the mode switch, are amplified to 10-V pulses, and are sent to the modulators via the respective FIAT racks. The other mode switch position is standby. The standby line delivers delayed pulses at the rate determined by the rate signals. The operation of the mode switch is described in Chapter 15.

INJECTOR TRIGGER GENERATOR. The injector trigger generator must provide sets of timing pulses for equipment associated with each of several beams. Some equipment is pulsed every time a beam pulse occurs. Some equipment is pulsed only for one beam or another. In general, the pulse repetition pattern may be different for each piece of equipment. A block diagram is shown in Fig. 14-12.

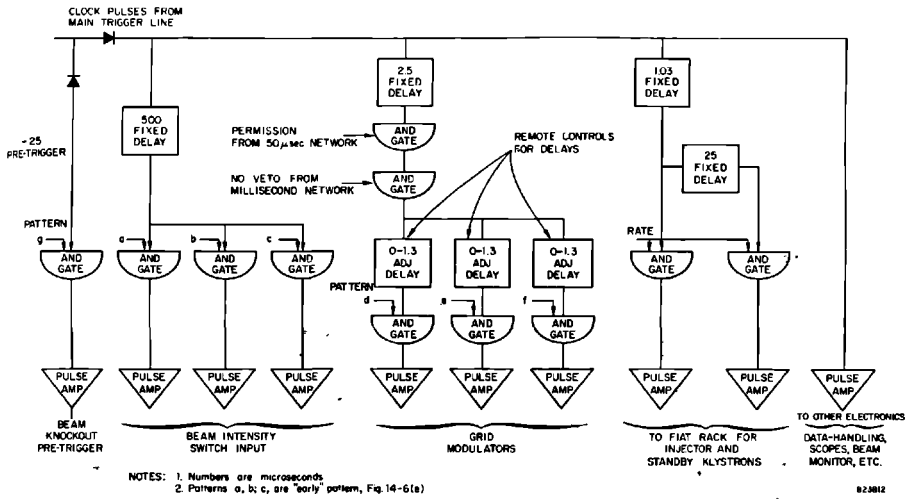

Figure 14-12 Block diagram of injector trigger generator.

The pulse intensity control requires special pretriggering. The injector trigger generator, therefore, requires a set of special pretrigger channels differing from the types found in the sector trigger generator.

The intensity control requires a trigger signal 2.3 msec before a new level is required. There are provisions for three levels, which may be called for in any sequence.

The previous clock pulse is fed through a delay line. The output of the delay line is gated by an "early" pattern signal to trigger the intensity control switch for the next pulse.

The injector modulator has three separate grid pulse modulators which allow selection of three different pulse lengths (see Chapter 8). This selection is independent of the selection of beam current. The circuit requires an input pulse of approximately 3.0 μ sec duration, instead of the standard 400 nsec. Each channel has a separate, remotely controlled, delay adjustment from 2.5 to 3.8 μ sec. The minimum delay within the grid modulator is 0.5 μ sec. The leading edge of the grid pulse is, therefore, adjustable from 3.0 to 4.3 μ sec after the clock. The trigger system is designed to use a nominal leading edge of the beam pulse 4.0 μ sec after the clock. The earlier triggering allows for one variety of beam loading compensation. All three grid pulses are shut off by the millisecond network of the machine protection system and are gated by the output of the 50- μ sec network of the machine protection system.

The beam knockout system requires a 25 μ sec pretrigger gated by a pulse pattern signal. Many other pieces of electronic equipment require standard clock pulses. These trigger channels are handled in the same manner as in the sector trigger generator.

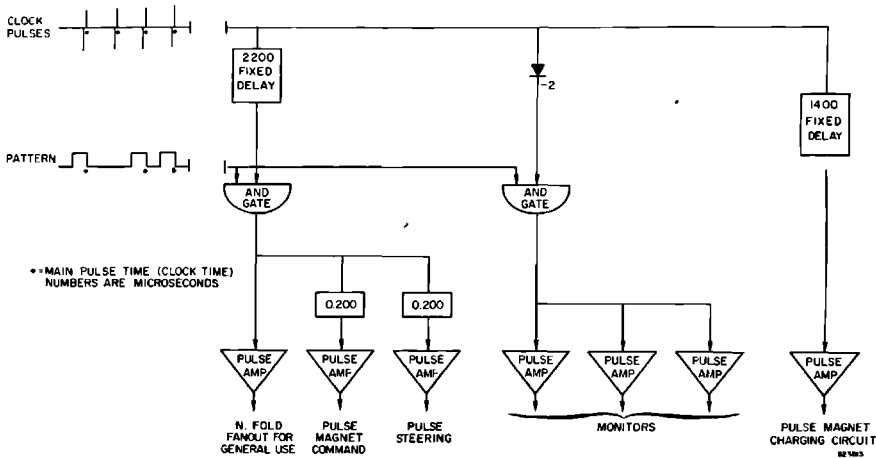

Figure 14-13 Block diagram of trigger channels for beam A (a portion of the switchyard trigger generator).

SWITCHYARD TRIGGER GENERATOR. The switchyard trigger generator must provide sets of timing pulses for equipment associated with each of several beams. Some equipment is pulsed only for one beam or another. In general, the pulse repetition pattern may be different for each piece of equipment. A block diagram of that portion of the switchyard trigger generator devoted to the A-beam is shown in Fig. 14-13.

The pulse magnets require special pretriggering. The switchyard trigger generator, therefore, has a set of special pretrigger channels differing from the types found in the sector trigger generator.

The previous clock pulse is fed through two delay lines. The output of the first delay line occurs at $-1400 \mu\text{sec}$ to recharge the storage capacitors in the magnet modulators. The output of the second line is gated by the appropriate pattern signal and yields a $500\text{-}\mu\text{sec}$ pretrigger to trigger the pulse magnet modulator for the next pulse.

Many other pieces of electronic equipment require $25\text{-}\mu\text{sec}$ pretrigger or standard clock pulses. These trigger channels are handled in the same manner as in the sector trigger generator.

Pattern generator (KWH)

The pattern generator subsystem in CCR enables the operator to produce separate pulse patterns for as many as six interlaced beams of different repetition rates, energies, and destinations, and to transmit each pulse to appropriate points along the accelerator (injector, sectors, beam switchyard, end stations, etc).

The pattern generator consists of four principal components, performing four principal functions (Fig. 14-14):

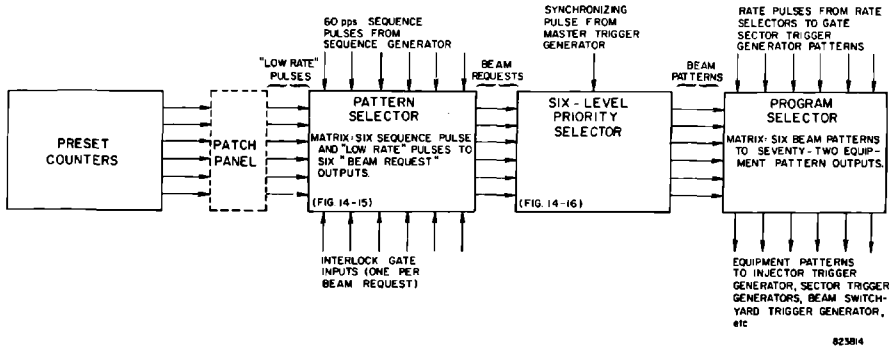

Figure 14-14 Block diagram of pattern generator subsystem.

1. A pattern selector which enables the operator to distribute any or all of the six sequence pulses to any or all of six "beam lines."
2. A set of counters to provide submultiples of 60 pulses/sec and to create pulse sequences of arbitrary complexity.
3. A priority selector which enables a priority (1-6) to be assigned to each beam line, so that whenever there are time-coincident pulses on two or more beam lines, only the one of highest relative priority is permitted to pass and all others are blocked.
4. A program selector which enables the pulses on each beam line to be transmitted to the desired points along the accelerator.

Suppose that the three interlaced beams given in the example under Section 14-1, entitled "Programming for Multiple Beams," are required, i.e., beam A—all available pulses, high energy (all thirty sectors), beam B—60 pulses/sec, medium energy (fifteen sectors), and null beam—60 pulses/sec. These requirements can be achieved by the settings shown in Table 14-1.

Since beam B and the "null beam" use different sequence pulses, none of their pulses coincide, and their relative priorities are immaterial. This is not true for beam A. On beam line 1, the priority selector passes only sequence pulses 3, 4, 5, and 6, yielding an irregular pulse pattern of 240 pulses/sec (Fig. 14-2c).

It is not necessary to use the first fifteen sectors for beam B. Any combination of sectors could be used, but it is generally easier to focus and steer a

Table 14-1

Beam	Beam line	Pattern selector (sequence pulses)	Priority selector (priority)	Program selector (sectors)
A	1	1, 2, 3, 4, 5, 6	3	1-30
B	2	2	2 or 1	1-15
Null	3	1	1 or 2	None

high-energy beam than a lower-energy beam, and it is customary to bring each beam pulse up to its final energy in the earliest available sectors.

In two sectors (27 and 28) near CCR, however, the sector trigger generators have been modified, and programming switches are provided in CCR for creating independent patterns for each of the sixteen klystrons, thus enabling beam energies to be adjusted in smaller increments than can be done by programming entire sectors.

Normally only two or at most three beams are in operation at a time. The ability to program as many as six beams facilitates switching back and forth as required between two beams of different energies or repetition rates destined to the same target. Provisions have been made for easily increasing the number of beam lines and priority levels if and when required.

Each of the three principal pattern generator units also performs certain other functions.

A functional logic diagram of the pattern selector is shown in Fig. 14-15. A 6×7 array of toggle switches allows synthesis of six beam request signals. A "high" rate may be created from the six 60-pulses/sec inputs from the sequence generator or a "low" rate from the counter-frequency dividers may be selected, for each beam request. The pattern selector also contains an interlock relay in each beam line by which each beam can be disabled from a number of remote points such as the beam switchyard and end stations. The

Figure 14-15 Functional logic diagram of pattern selector. A 6×7 array of toggle switches allows synthesis of six beam requests from six 60-pulses/sec inputs or from the counter inputs.

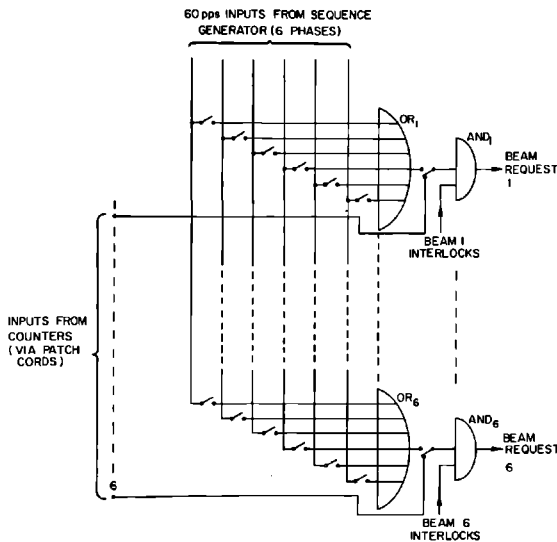

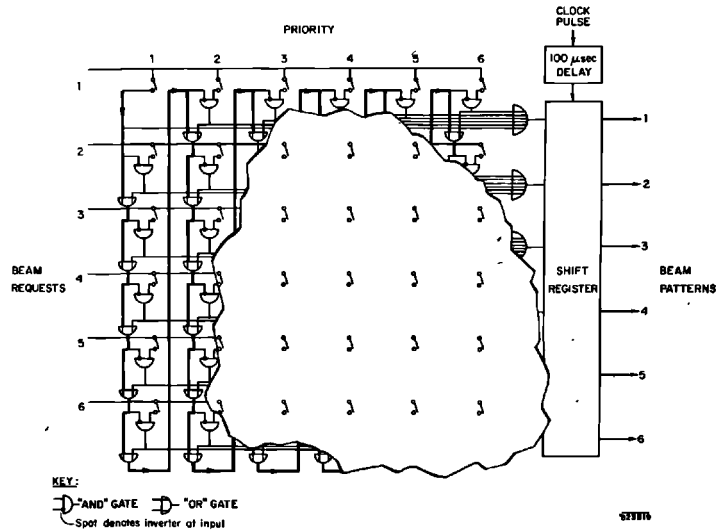

Figure 14-16 Simplified logic diagram of priority selector. The "veto circuit" (heavy line) insures that any output pattern cancels every lower-priority request. The shift register changes the output pattern immediately after a beam pulse and prevents scrambling of patterns when toggle switches are changed.

relay prevents the pattern selector from transmitting any pulses for a desired beam until all such remote points indicate permissible conditions of personnel and machine safety and experimental readiness for that particular beam. Alternatively, once the beam is operating, it can be turned off within one pulse period from any of these remote points in case of an emergency.

The operation of the priority selector is illustrated in Fig. 14-16 (the actual mechanization is somewhat more complex). A "veto" circuit (heavy line) insures that any output pattern inhibits any simultaneous lower-priority request. Thus, in case of time-coincident requests on two or more beam lines, the priority network blocks all such pulses but the one of highest relative priority. If the output of the priority network were used directly for the beam patterns, the patterns would change at some arbitrary time between beam pulses when a toggle in the pattern selector or the priority selector is changed. If the patterns changed after the pulsed magnets in the switchyard were triggered but before the klystrons were triggered, the resultant scrambled beam pulse could cause trouble. Immediately after each beam pulse, the output of the priority network is loaded into a shift register, which then cannot be changed until after the next beam pulse. The effect of this register is to make the actual beam patterns 1/360 sec later than the corresponding requests.

The program selector has a 6×72 array of toggle switches in a circuit similar to the pattern selector to allow synthesis of equipment patterns from the six beam patterns. An additional array of switches at the operator's

console allows creation of individual patterns for the sixteen klystrons of Sectors 27 and 28. The equipment patterns are chopped at 360 pulses/sec to allow ac-coupled transmission to the trigger generators. The normal chopper output produces the standard pattern of Fig. 14-6b; an inverted chopper signal can be used to produce the early pattern of Fig. 14-6e. The patterns for the klystrons are also gated by the appropriate signal from the rate selector, to provide the klystron pattern of Fig. 14-6d, thus providing protection against inadvertently applying accelerated pulses to the klystrons at higher repetition rates than those of the respective standby pulses from the rate selectors. Since they are changed very infrequently, the chopping and gating at each program selector output are not determined by switch settings but by jumper connections inside the selector.

Subsidiary components include a six-channel counter-frequency divider, whose counting cycle lengths are easily and independently adjustable. The channels may be interconnected with one another and with the pattern selector through an associated patch panel, for numerous special purposes.

Operated as frequency dividers, they may be used to produce any desired submultiples of any of the six sequence pulse trains.

Operated as counters, they may be used to produce aperiodic pulse trains of different lengths for timing sequences of events that must occur during a relatively long pulse period. For example, the starting times of a wand target and bubble chamber and the starting time and duration of a quiet (null beam) period can be adjusted independently with respect to the occurrence of a low-frequency positron beam.

References

- 1 Counting Note, File No. CC2-1 in "Radiation Laboratory Counting Handbook," Rept. No. UCRL 3307 (Rev.), Lawrence Radiation Laboratory, University of California, Berkeley, California (1959).
- 2 A. Barna, "Sector Takeoff Transformer for the 2-Mile Accelerator," Technical Note No. SLAC-TN-64-69, Stanford Linear Accelerator Center, Stanford University, Stanford, California (Aug. 1964).